

interatletika™

PRODUCTION AND SALE OF SPORTS GOODS

Customer support:
+38 095 273 81 53
play.interatletika.com

DATA SHEET

Sports complex Workout SM80x

The product meets the requirements of EN16630-2015.

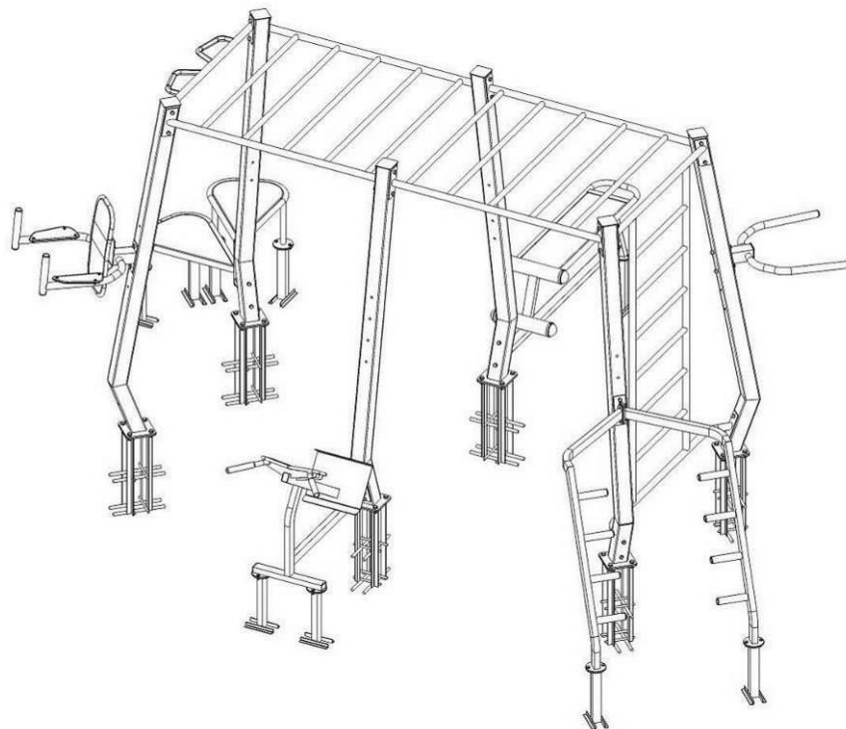

1. GENERAL INFORMATION

Purpose and content of this document. This document contains a general description of the equipment, information on installation, intended use, maintenance, current repair and manufacturer's warranty.

Distribution of this document for product modifications. The manufacturer can make changes to the design of the product, aimed at improving its characteristics, changing the design, etc. This document may not contain a description of such changes, but applies to such modified products.

2. MAIN TECHNICAL DATA AND CHARACTERISTICS

№	Product code	Name	Dimensions			Weight, kg	Fall height, mm
			Length, mm	Width, mm	Height ¹ , mm		
1	SM800	Sports complex Workout	3058	1453	2425	152	1358
2	SM801	Sports complex Workout	4590	3664	2425	312	1358
3	SM801.1	Sports complex Workout	3685	2585	2425	241	1358
4	SM801.2	Sports complex Workout	5322	3685	2425	324	1358
5	SM801.3	Sports complex Workout	4932	3685	2425	230	1358
6	SM801.4	Sports complex Workout	4301	3685	3491	381	1458
7	SM802	Sports complex Workout	5832	4927	2425	516	1358
8	SM802.1	Sports complex Workout	5832	4927	2968	551	1485
9	SM802.2	Sports complex Workout	5608	4927	2425	485	1352
10	SM803	Sports complex Workout	5819	4775	3484	594	1484

1. Height of the point above ground level (coverage).

Product appearance

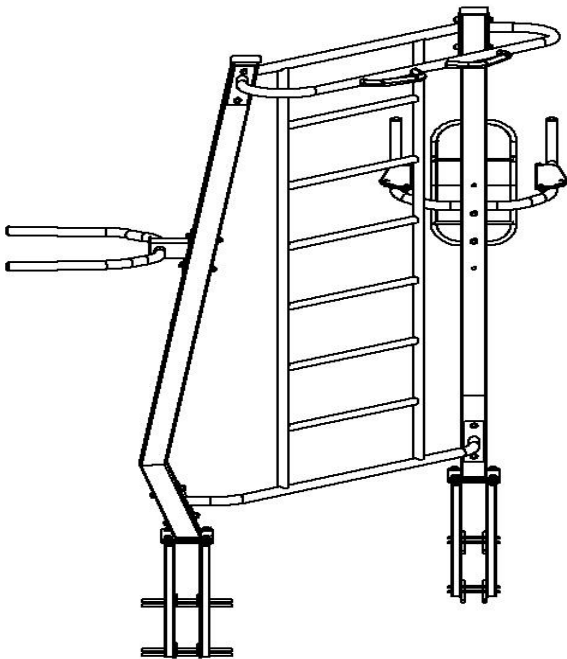
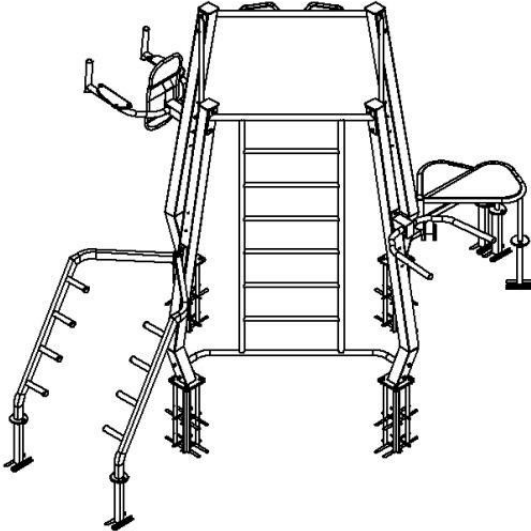
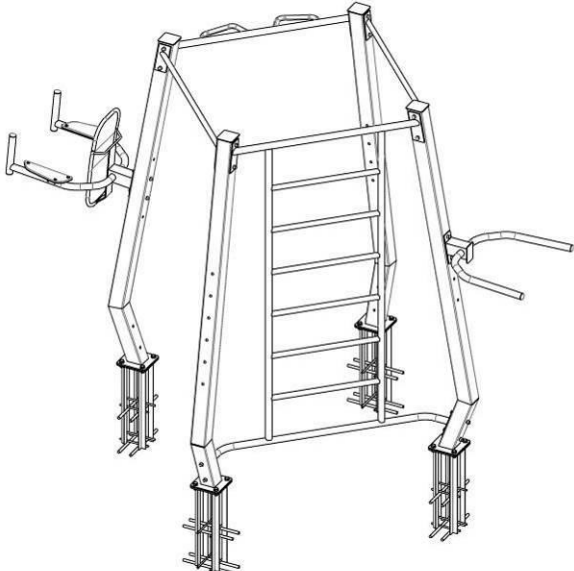
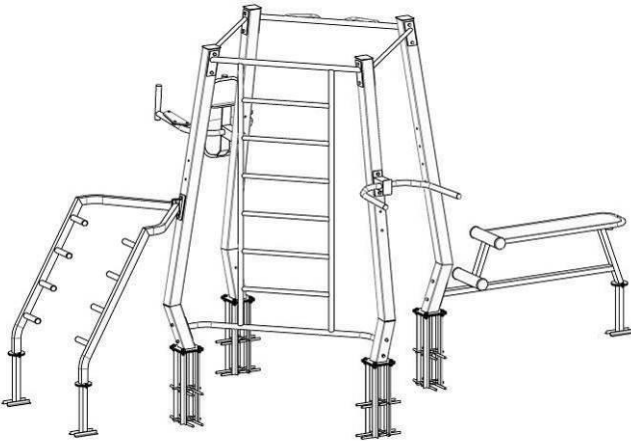
Sports complex Workout	SM800	Sports complex Workout	SM801
 <p>A line drawing of a large, multi-functional exercise machine. It features a central vertical column with a horizontal bar at the top. On the left side, there are two long, angled arms extending outwards. The machine is supported by four legs, each with a set of rollers at the base. A central panel with horizontal bars is visible on the right side.</p>		 <p>A line drawing of a similar exercise machine to SM800, but with a different configuration of arms and a more complex base structure. It has a central vertical column and a horizontal bar at the top. The base consists of four legs with rollers, and there are additional structural elements on the right side.</p>	
Sports complex Workout	SM801.1	Sports complex Workout	SM801.2
 <p>A line drawing of the SM801.1 exercise machine, showing a different view or configuration. It features a central vertical column and a horizontal bar at the top. The base has four legs with rollers. The machine is designed for a variety of exercises, including those involving the arms and torso.</p>		 <p>A line drawing of the SM801.2 exercise machine, showing another view or configuration. It has a central vertical column and a horizontal bar at the top. The base consists of four legs with rollers. The machine is designed for a variety of exercises, including those involving the arms and torso.</p>	

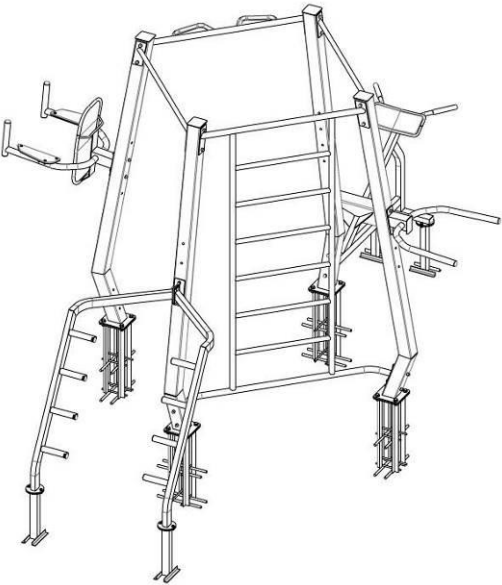
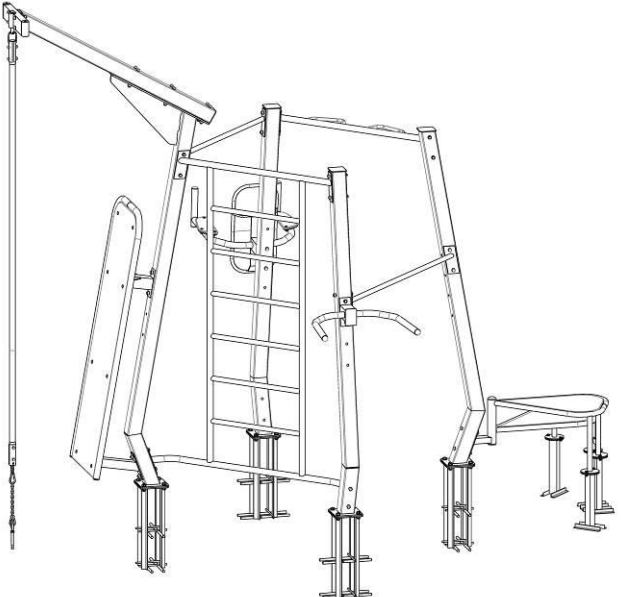
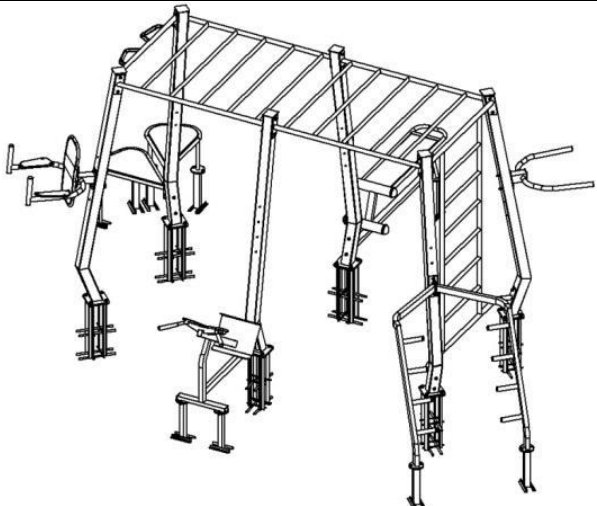
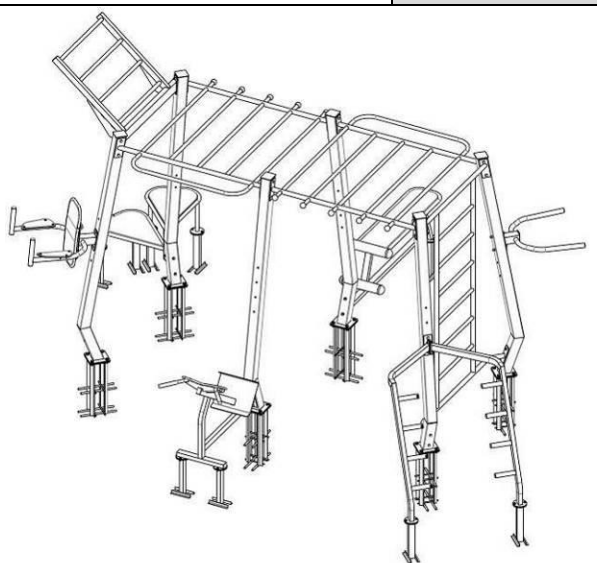
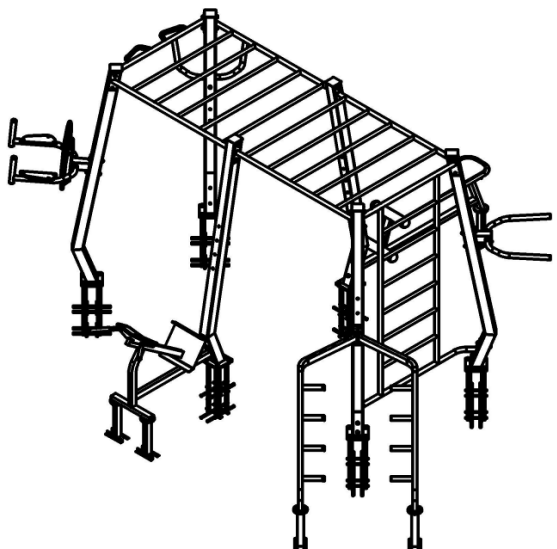
Sports complex Workout	SM801.3	Sports complex Workout	SM801.4
			
Sports complex Workout	SM802		
			
Sports complex Workout	SM802.1	Sports complex Workout	SM802.2
			

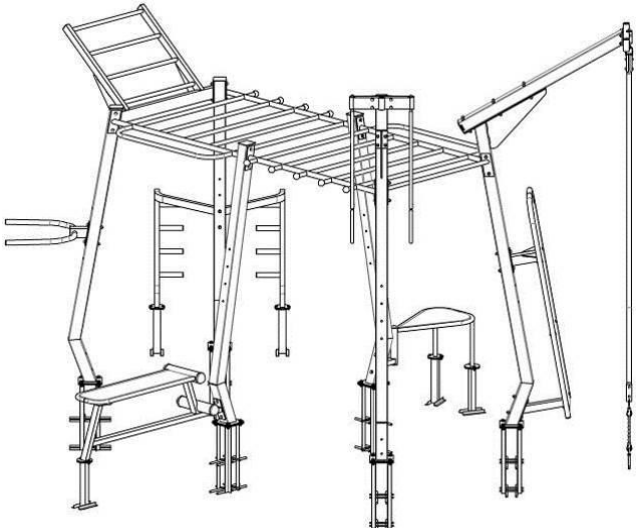
Sports complex Workout	SM803	
		

3. COMPLETENESS AND CHARACTERISTICS OF THE MAIN PARTS OF THE PRODUCT

See Appendix A for the complete set and characteristics of the product components.

4. PROCEDURE FOR ASSEMBLING AND INSTALLING THE PRODUCT

Tools and accessories. The product does not include the tools required for assembly and installation.

Product assembly and installation procedure.

- 1) Mark out the area according to the dimensions shown in Appendix B.
- 2) Dig pits for concreting in accordance with the concreting schemes, Picture 1, Picture 1.1.

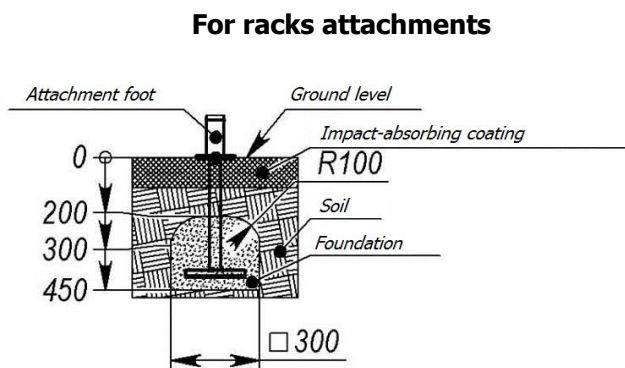
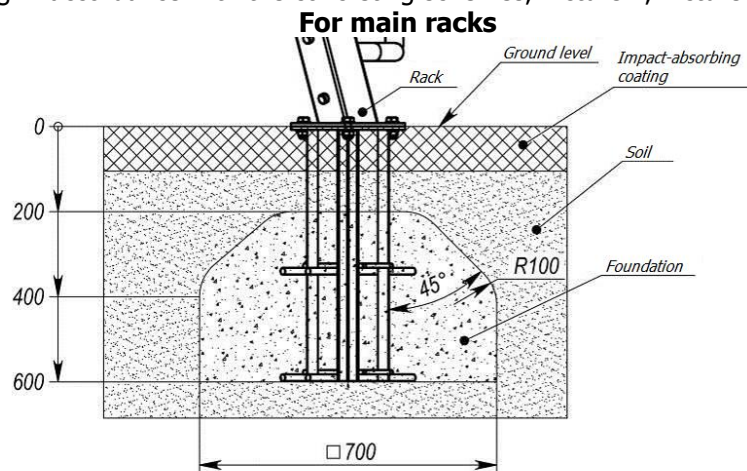

Picture 1 - Concreting schemes

For racks SM800

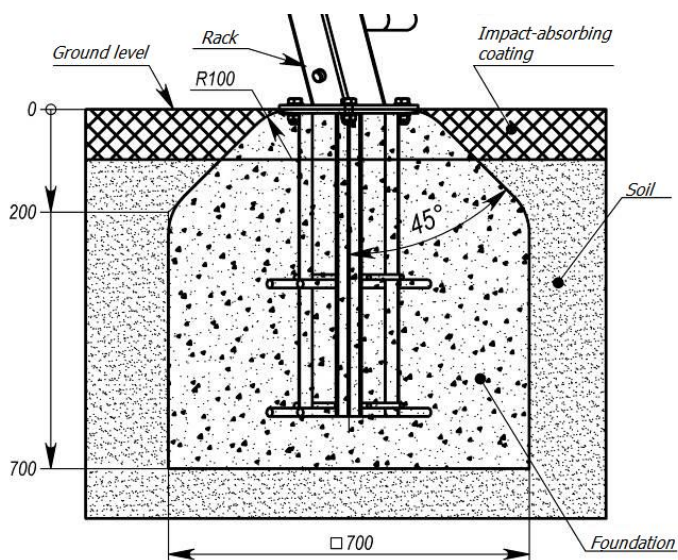

For ropes

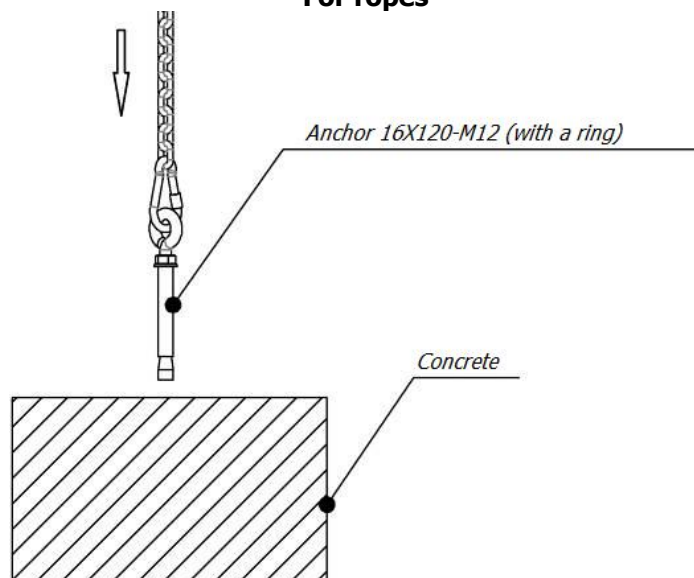

Picture 1.1 – Concreting scheme

3) Assemble the product according to the picture (see Appendix A).

Example of an impact-absorbing coating

No p/n	Material - coating ¹	Description	Minimum layer thickness ¹ , mm	Max. fall height, mm
1	Concrete/stone	—	—	≤1 000
2	Bitumen-bonded surface	—	—	≤1 000
3	Natural soil	—	—	≤1 200
4	Lawn	—	—	≤1 500
5	Wooden mulch	Shredded coniferous bark, particle size from 20 to 80 mm	200	≤2 000
			300	≤3 000

6	Sawdust	Mechanically shredded wood (not wood-based materials), without bark and leaves, with a particle size of 5 to 30 mm	200	≤2 000
			300	≤3 000
7	Sand ^{2, 3,}	Particle size from 0.2 to 2 mm	200	≤2 000
			300	≤3 000
8	Gravel ^{2, 3}	Particle sizes from 2 to 8 mm	200	≤2 000
			300	≤3 000
9	Other materials and layer thicknesses	HIC tested according to EN 1177		Critical fall height according to test results

1 Add 100 mm to the minimum layer thickness for cushioning loose material.

2 No silt or clay fractions should be present; the particle size can be determined by sieve analysis according to EN 933-1.

3 Not suitable for exercise machines where a firm, stable user position is required.

5. PRODUCT INSTALLATION SCHEME

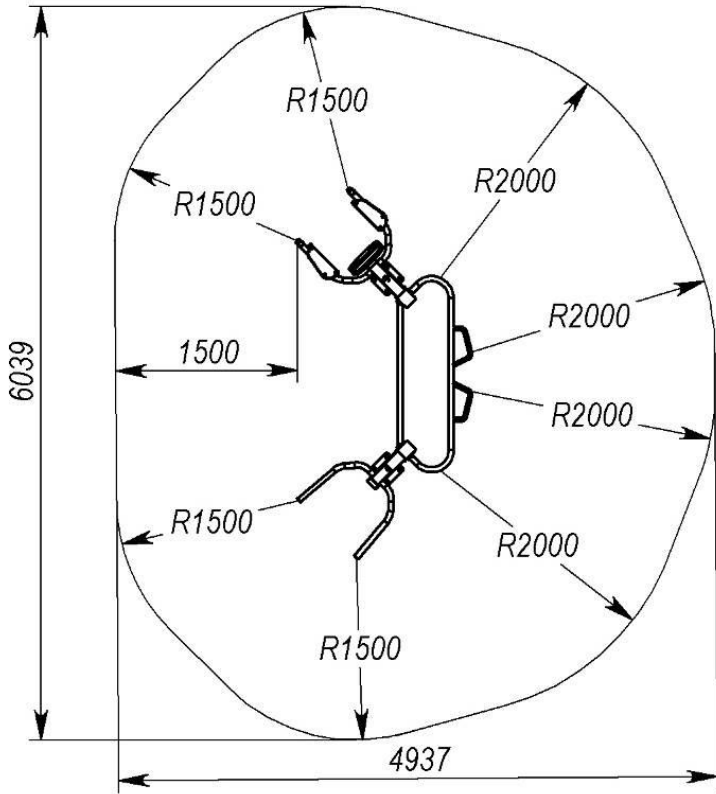
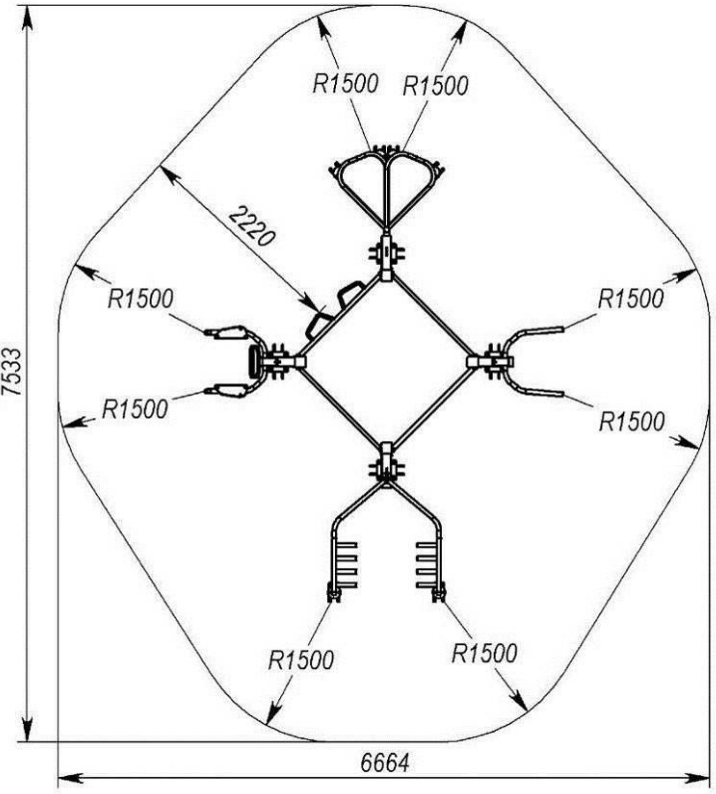
Safety zone	
Sports complex Workout	SM800
 <p>Diagram illustrating the safety zone for the SM800 product. The layout is contained within a rounded rectangular area with a total height of 6039 and a total width of 4937. The equipment is arranged in a central vertical column. The top and bottom horizontal arms have a radius of R1500. The vertical central column has a radius of R2000. A horizontal dimension of 1500 is indicated from the left edge to the start of the central column.</p>	
Sports complex Workout	SM801
 <p>Diagram illustrating the safety zone for the SM801 product. The layout is contained within a rounded rectangular area with a total height of 7533 and a total width of 6664. The equipment is arranged in a diamond-shaped pattern. The top and bottom horizontal arms have a radius of R1500. The vertical central column has a radius of R1500. A horizontal dimension of 2220 is indicated from the left edge to the start of the central column.</p>	

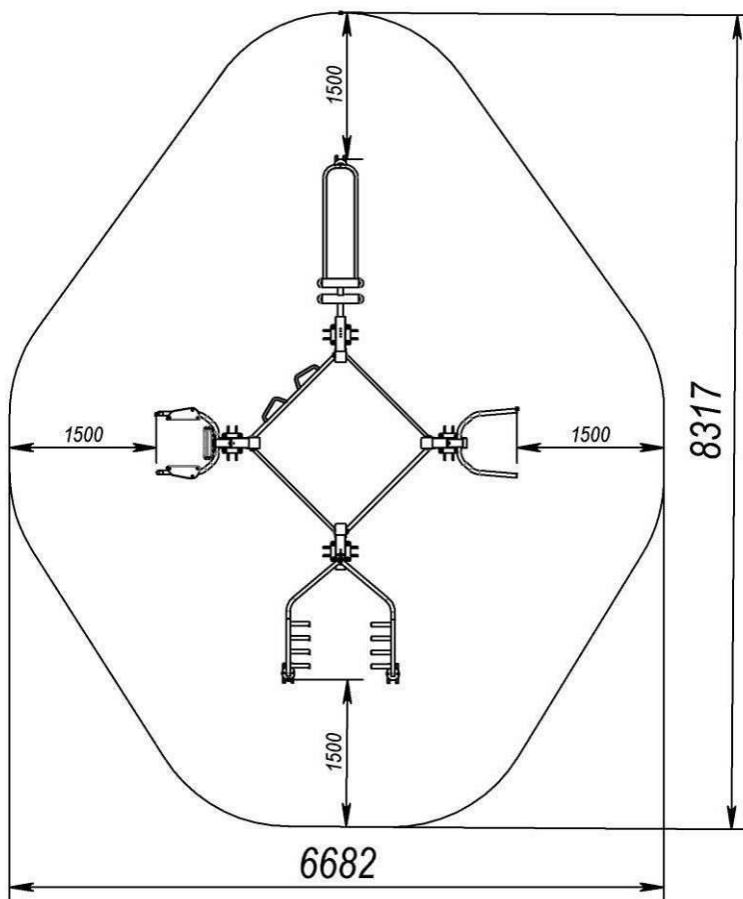
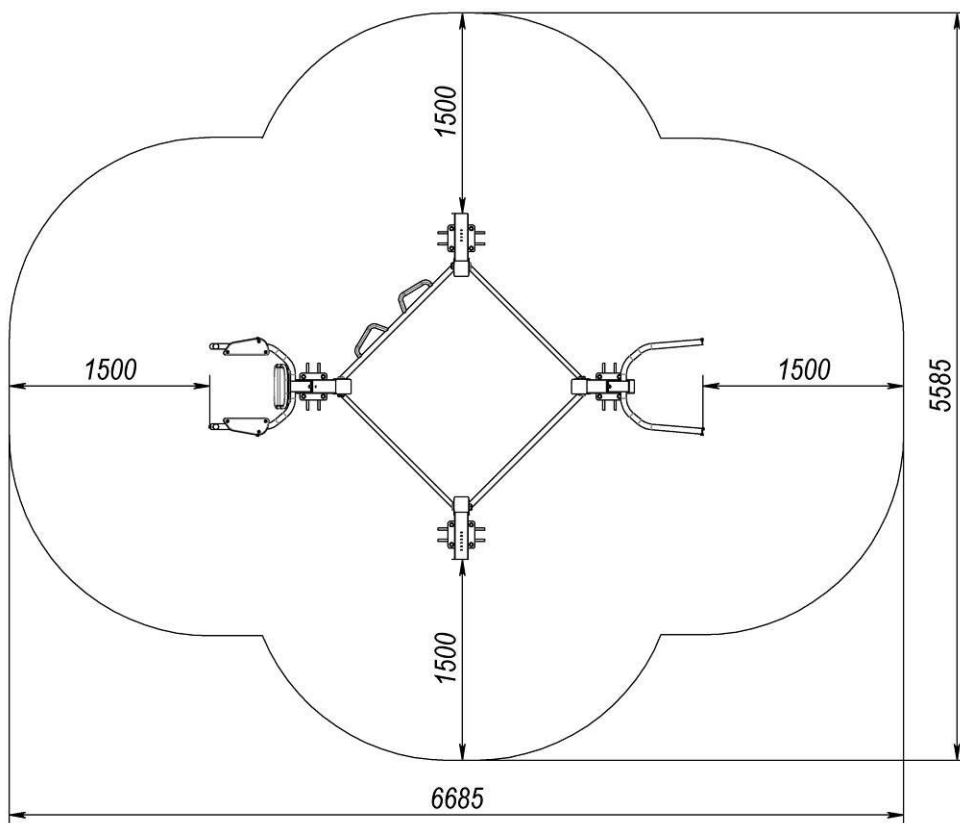

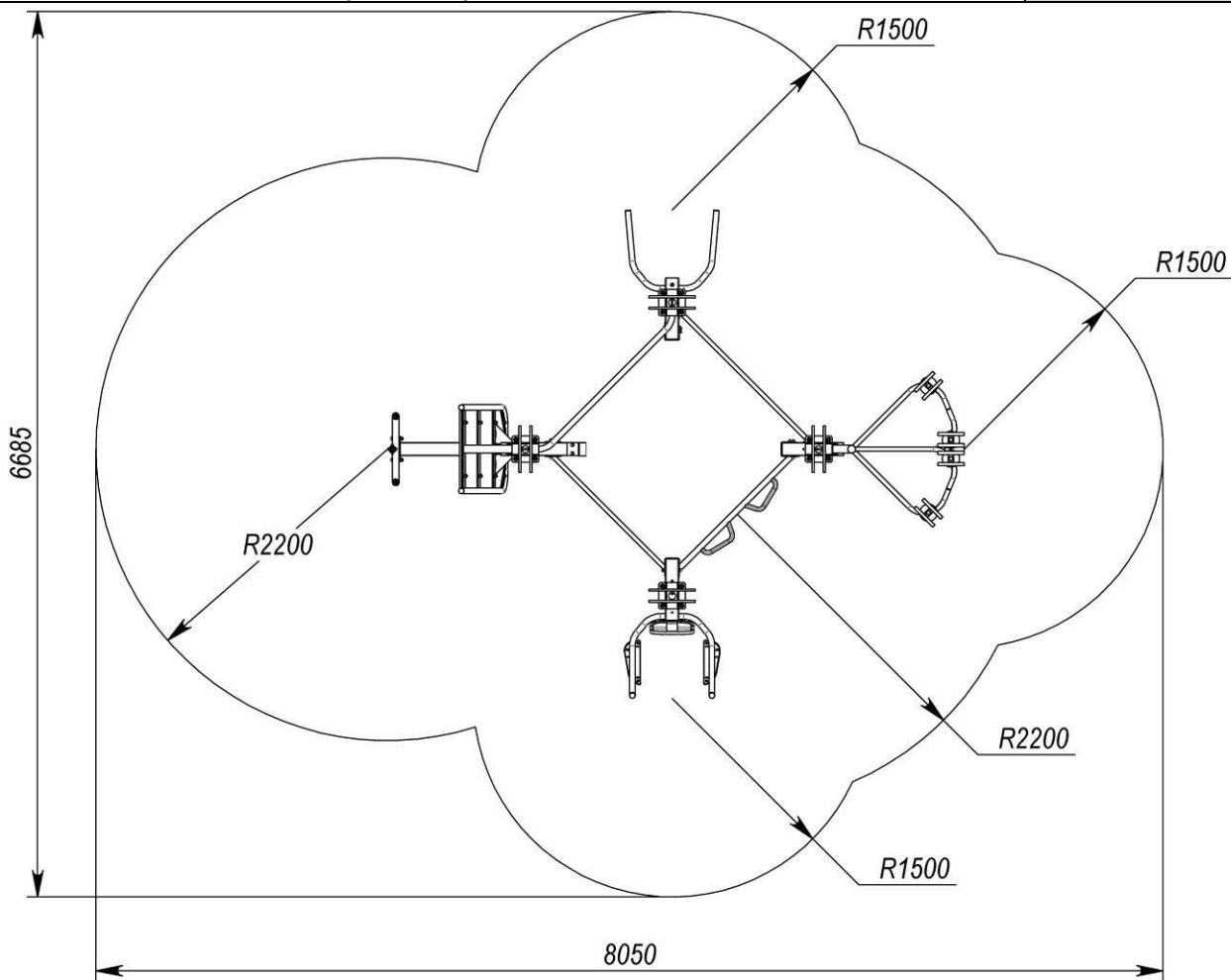
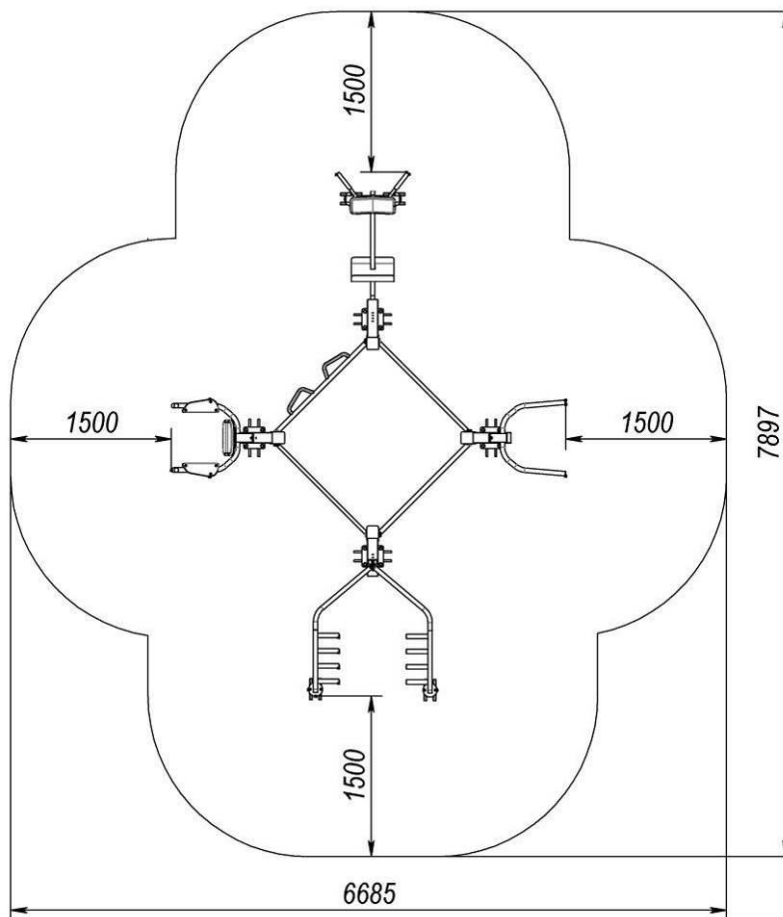

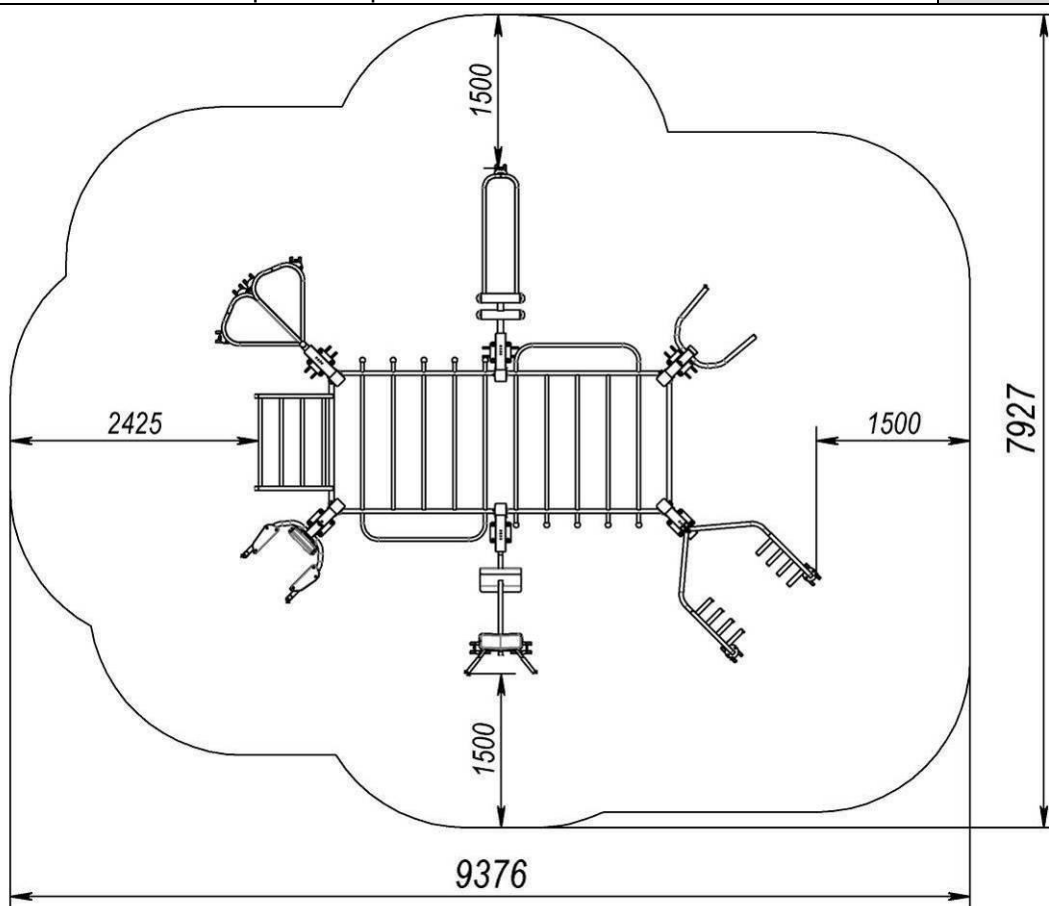
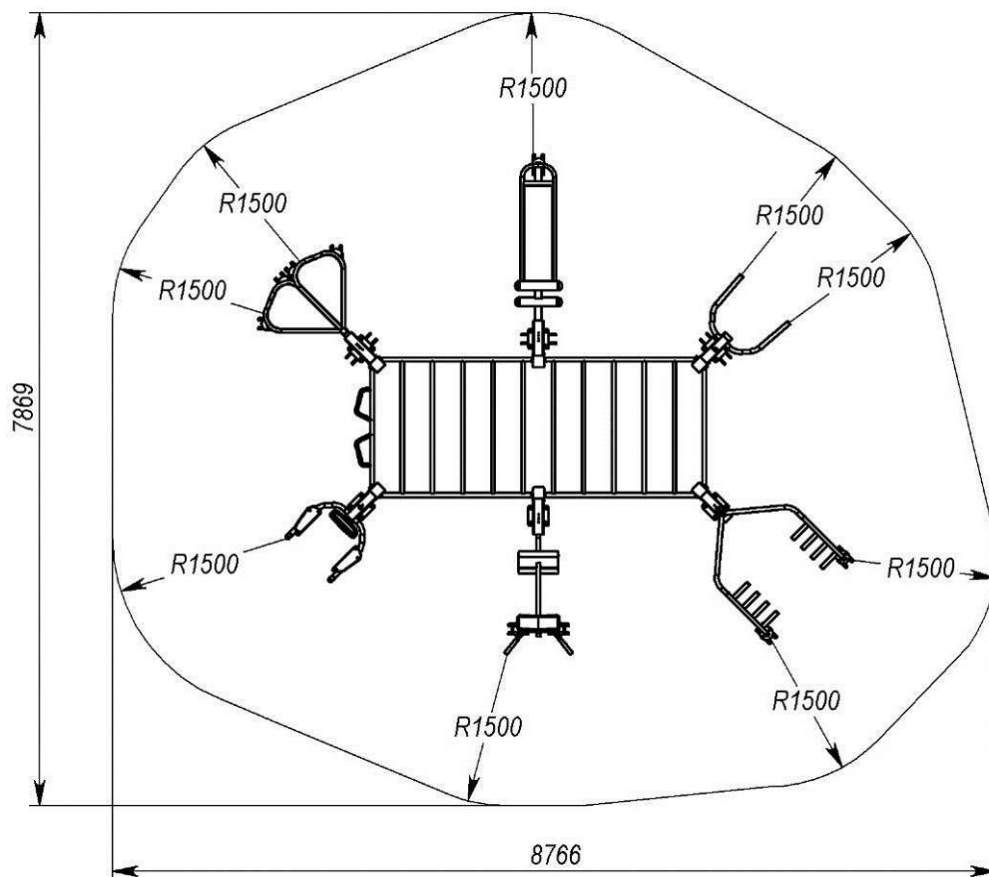

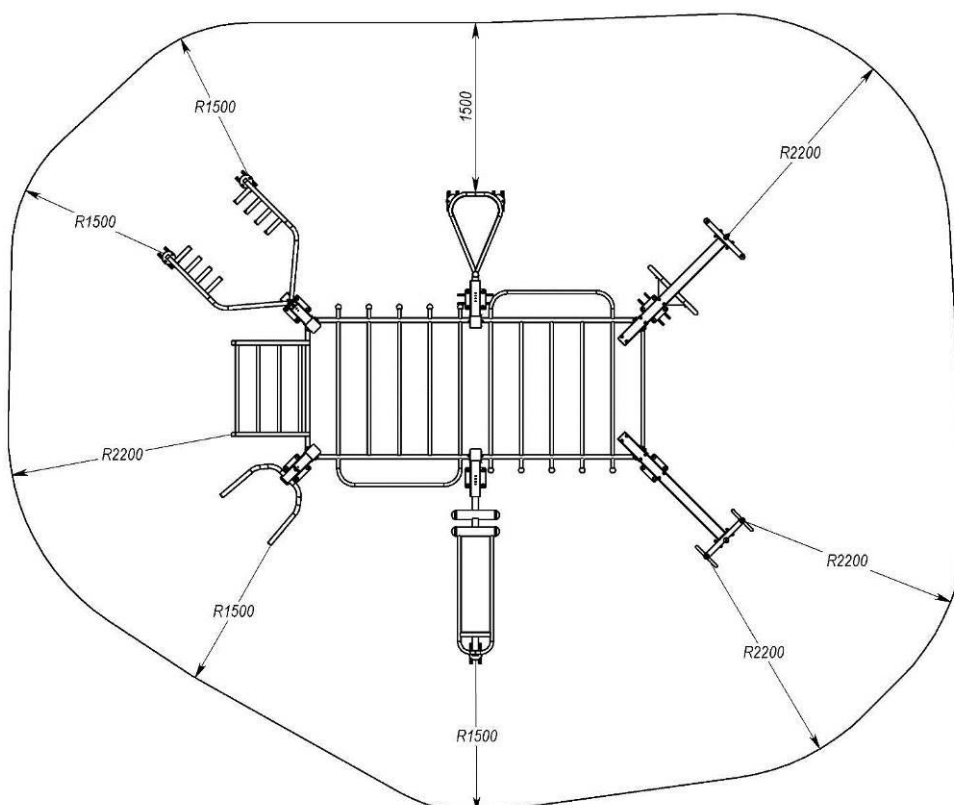
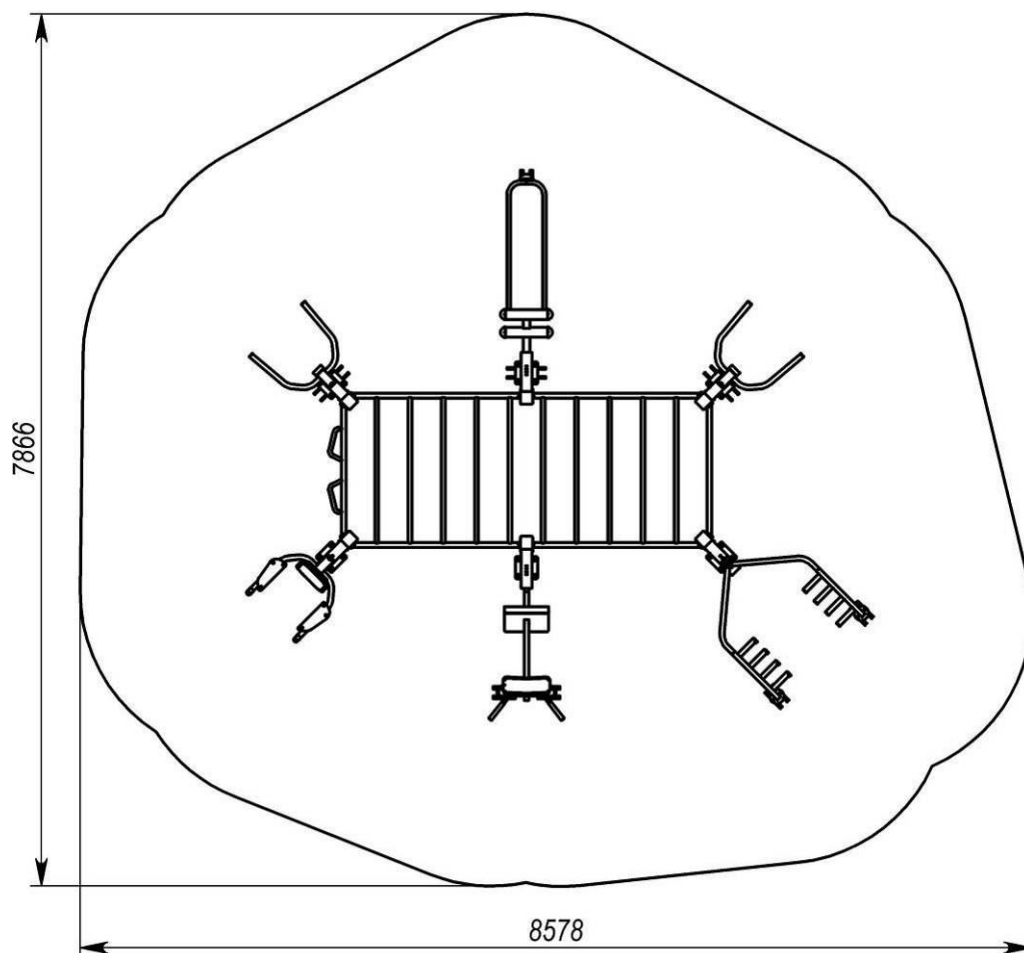

6 PRODUCT USE

Do not use the product until it has been fully and completely installed.

The product must not be used by users of a different age category.

The product must not be used by users of a different weight category.

Before using the product, clear the safety area of any unnecessary objects that may cause damage to the user (debris, tools left over from assembly and installation, etc.).

Do not use the product in adverse weather conditions (ice, snow, rain, hail, strong winds, etc.), which may cause injury to the user.

7. PRODUCT MAINTENANCE

You have purchased high-quality and reliable equipment. In the process of its production, the requirements of regulatory and technical documents of Ukraine, the CIS countries and the European Union regulating the production of children's gaming equipment were taken into account. However, it should not be forgotten that when operating any technical product, certain rules and requirements must be followed. Despite the fact that our product is of high quality and reliability, this rule applies to it in full. You should be aware that the implementation of the following rules and recommendations for product maintenance is aimed at ensuring that your child, the child of your friends or acquaintances is safe and no unforeseen factors threaten his health, life.

Remember that the operation of the product is accompanied by the influence of various negative factors on it, a complete list of which cannot be predicted. Among them, an important place is occupied by natural factors and factors caused by human influence on equipment. As a rule, their action initially leads to disruptions in the appearance of the product. Thus, under the influence of factors caused by the exploitation of a person, there may be damage to the integrity of the paint coating of parts made of wood, in the form of scuffs, chips, incisions, and when exposed to parts made of metal, damage to the paint coating in the form of nicks, chips, abrasion, etc. This leads to the emergence and development of defects that can be the cause of the destruction of the product. The product is particularly dangerous if it is used for other than its intended purpose, if the permissible loads are exceeded, or if vandalism occurs, as these factors can cause irreversible changes in the structure of the material from which the product is made, leading to destruction.

The maintenance of the product implies, first of all, the responsibility of the user to comply with all recommendations provided in this document, starting with a daily inspection of the external condition of the product before operation.

Daily inspection of the product is a very important procedure. With its help, you can timely detect any changes in the appearance of the product (deformation of individual parts, deformation of the structure as a whole or part of it, damage to parts, cracks of welds, as well as the absence of fastening of parts of the product, etc.).

Before using the product, check its operability, absence of damage, dirt on the product, sharp edges, reliability of fixing the structure, absence of unnecessary objects on the surface of the site. If the product is damaged, fully or partially inoperable, or has any other defects, do not use it.

During operation it is also necessary to inspect the condition of the product periodically - the current inspection. It includes an external inspection of the product, checking its operability (in the presence of moving elements - the smoothness of the movement of mechanisms, compliance with operating modes, etc.). Current inspection allows you to detect malfunctions caused by the operation of equipment, climatic conditions, acts of vandalism and other factors, until they reach a critical level and the destruction of the product. The current inspection is carried out in order to detect foreign objects that may threaten the user and lead to violations of the functioning of the product. The frequency of the current inspection is set by the owner taking into account the operating conditions. If you do not have sufficient technical knowledge and skills to conduct such inspections, we recommend you to contact the authorized specialists of the manufacturer in order to obtain advice.

Every three months, a scheduled inspection should be carried out, which primarily concerns the foundation part, load-bearing elements and connection nodes of elements (their integrity and degree of deterioration).

The main annual inspection must be carried out annually by authorised specialists of the manufacturer. During the inspection, the technical condition of the equipment shall be assessed for compliance with safety requirements. The degree of deterioration and damage to wooden elements and their ability to withstand the applied loads, damage, corrosion of metal elements and the impact of these factors on the safety of the product are determined. The inspection also helps to identify the impact of repairs, if any, on the safety of the equipment.

Based on the results of the inspection, a maintenance procedure is carried out to eliminate the identified discrepancies in the product's operation. This procedure includes assessing the condition of parts and assemblies, replacing worn parts, and restoring the integrity of protective coatings. The results of the inspections, as well as the procedures carried out as a result of the inspection and maintenance of the product must be properly documented in the Registration Journal, which is an integral part of this passport. The owner of the product must keep the acts of maintenance of the product, acts of repair work done.

Appendix A

SM800 – Sports complex Workout

Square profile of the racks 100 x100

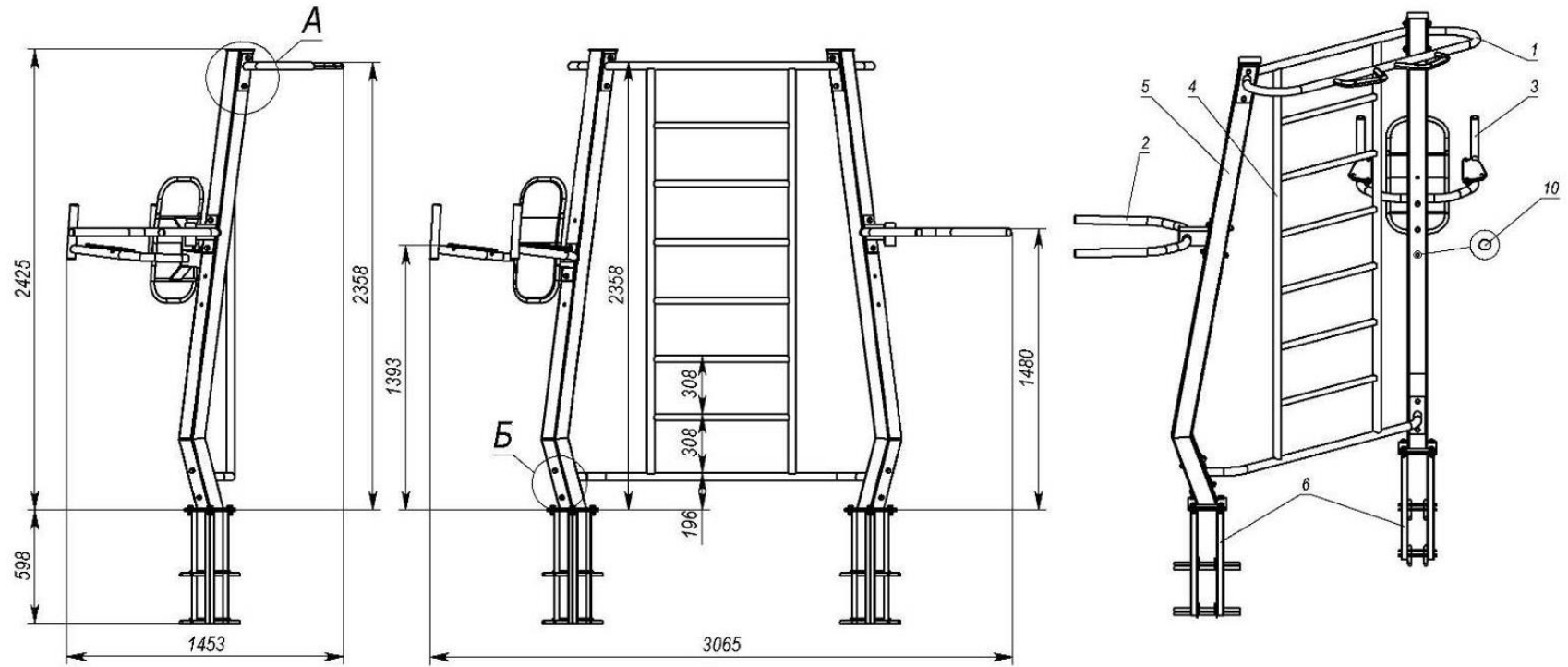

A (1:5)

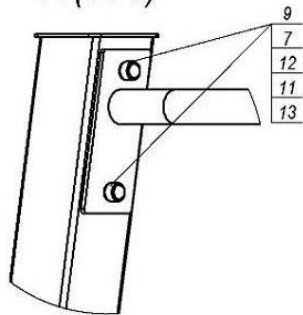

B (1:5)

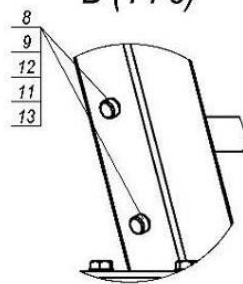

Pos.	Name	Weight, kg	Q-ty	Note
1	Canopy "Horizontal bar with handles"	12.6	1	
2	Canopy "Beams"	6.2	1	
3	Canopy "Arm press"	18.3	1	
4	Canopy "Wall bar"	31.3	1	
5	Rack 2.6 m	31.8	2	
6	Embedment 600mm assembly	9.3	2	
7	Bolt M10x130 GOST 7798		4	
8	Bolt M10x120 GOST 7798		8	
9	Nut m10 DIN985		12	
10	Plug ZDO 15x12		8	
11	Cap S17	1.83	12	
12	Cap f17		12	
13	Washer 10 GOST11371		24	

SM801- Sports complex Workout

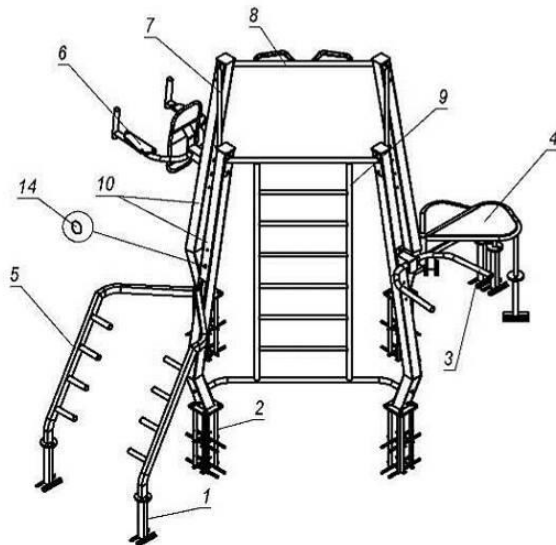
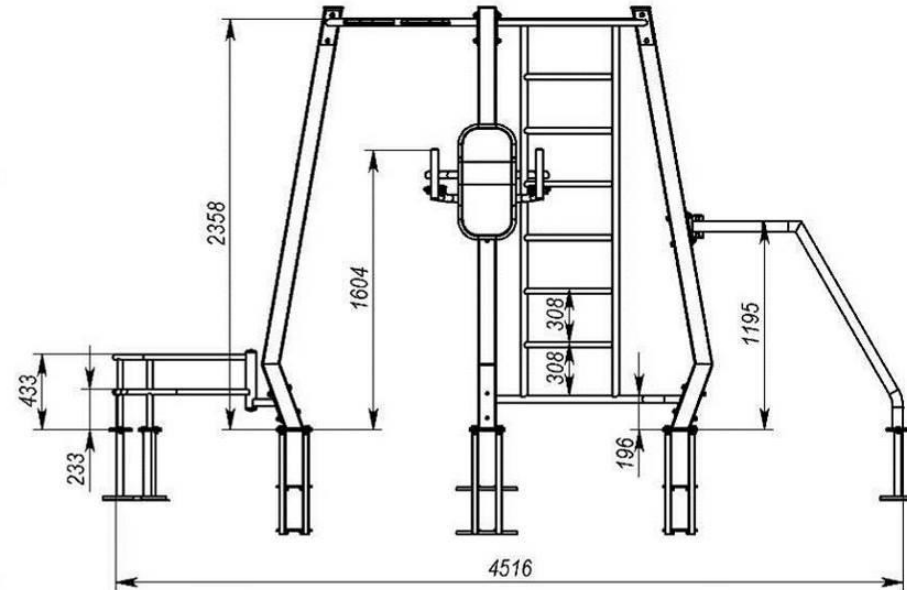
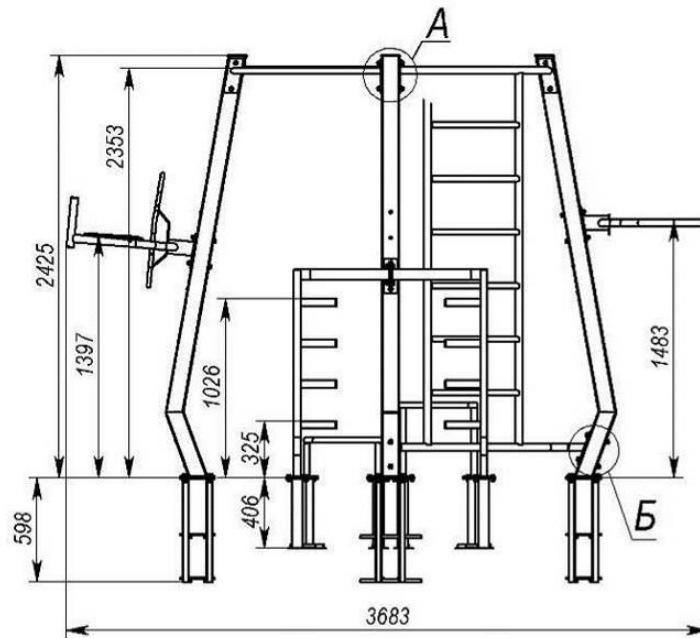

A (1 : 10)

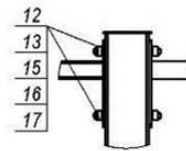

B (1 : 10)

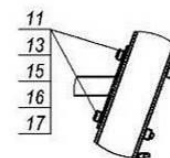

Pos.	Name	Weight, kg	Q-ty	Note
1	Embedment 400mm assembly	2.3	6	
2	Embedment 600mm assembly	9.3	4	
3	Canopy "Beams"	6.2	1	
4	Canopy "Platform for steps"	32.3	1	
5	Canopy "Handrail"	23.5	1	
6	Canopy "Arm press"	18.3	1	
7	Canopy "Horizontal bar 1.2 m"	4.8	2	
8	Canopy "Horizontal bar with handles"	9.9	1	
9	Canopy "Wall bar"	31.3	1	
10	Rack 2.6 m	31.8	4	
11	Bolt M10x120 GOST 7798		12	
12	Bolt M10x130 GOST 7798		8	
13	Nut M10 DIN985		20	
14	Plug ZDO 15x12		24	
15	Cap S17	1.83	20	
16	Cap f17		20	
17	Washer 10 GOST11371		40	

SM801.1 – Sports complex Workout

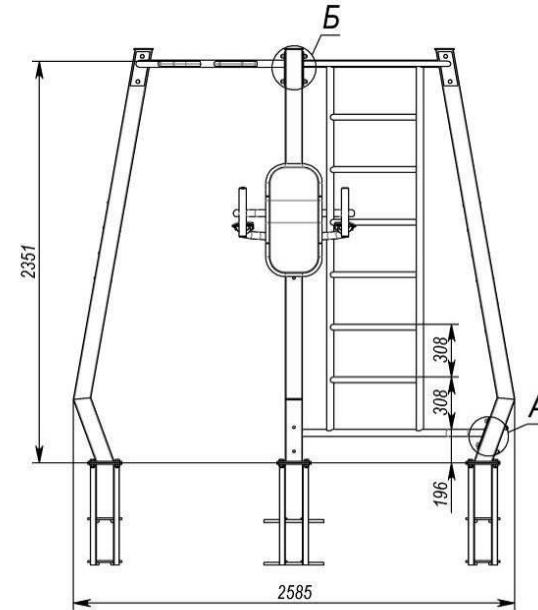
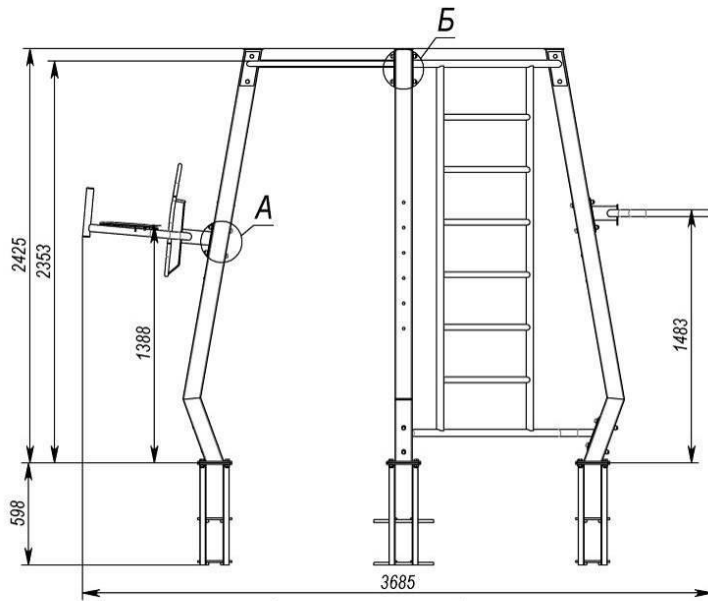

A (1 : 4)

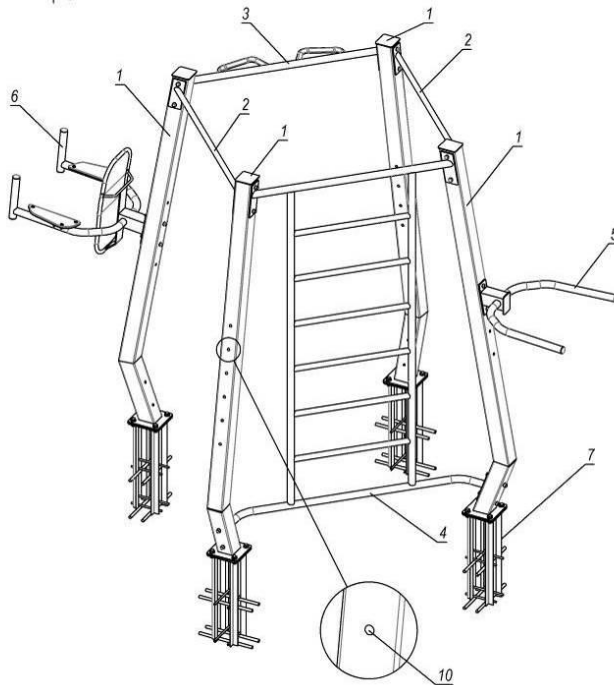
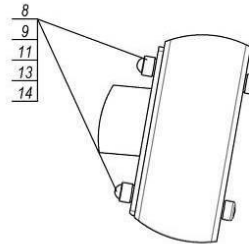

Б (1 : 4)

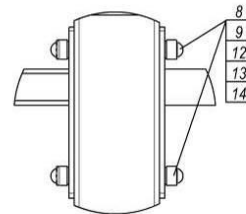

Pos.	Name	Weight, kg	Q-ty
1	Rack 2.42 m	32	4
2	Canopy "Horizontal bar 1.2 m"	5	2
3	Canopy "Horizontal bar with handles"	9	1
4	Canopy "Wall bar"	31	1
5	Canopy "Beams"	6	1
6	Canopy "Arm press"	19	1
7	Embedment 600mm assembly	9	4
8	Cap f17		16
9	Cap S17		16
10	Plug ZDO 15x12 (for tech. holes)		32
11	Bolt M10x120 GOST 7798		8
12	Bolt M10x130 GOST 7798		8
13	Nut M10 DIN985		16
14	Washer 10 GOST11371		32

SM801.2 – Sports complex Workout

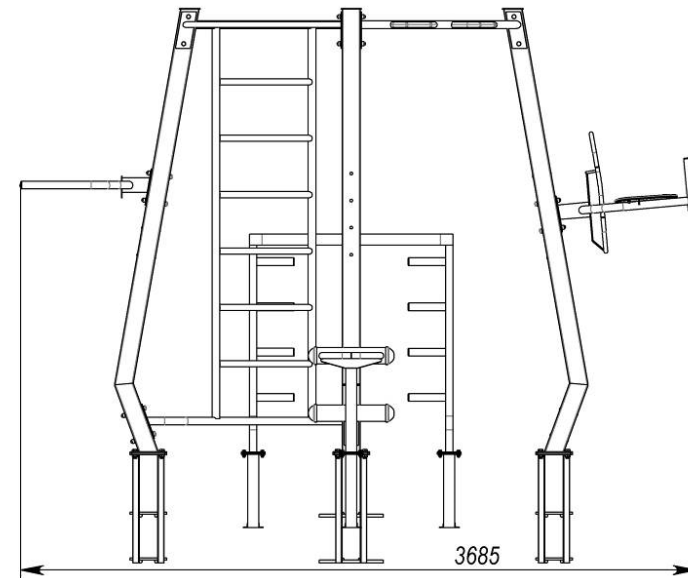
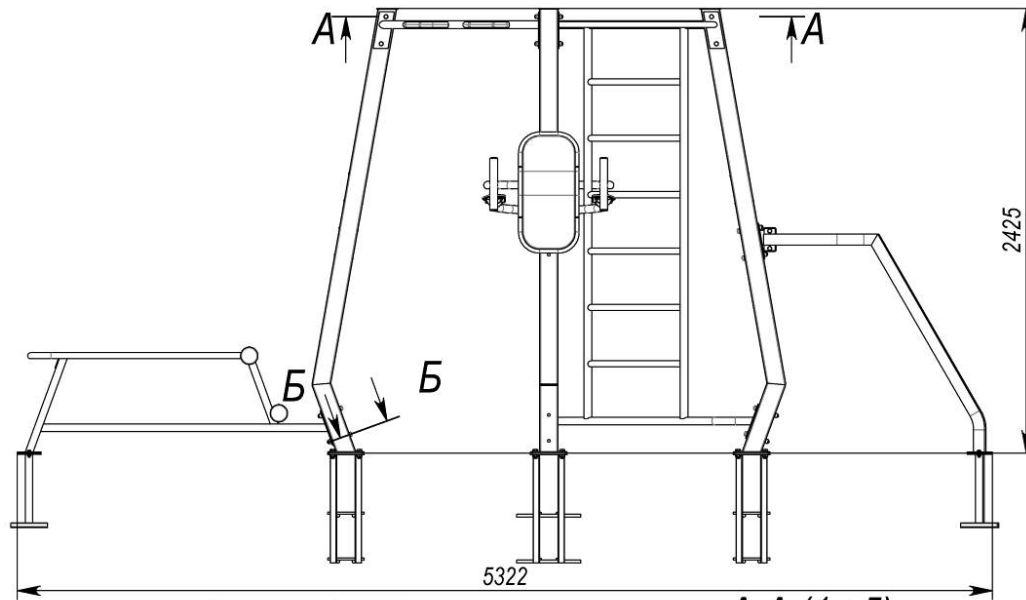

A-A (1 : 5)

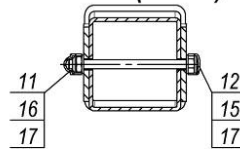

B-B (1 : 5)

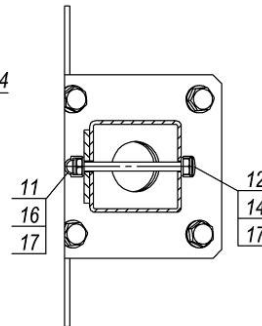

Not mentioned dimensions see SM801

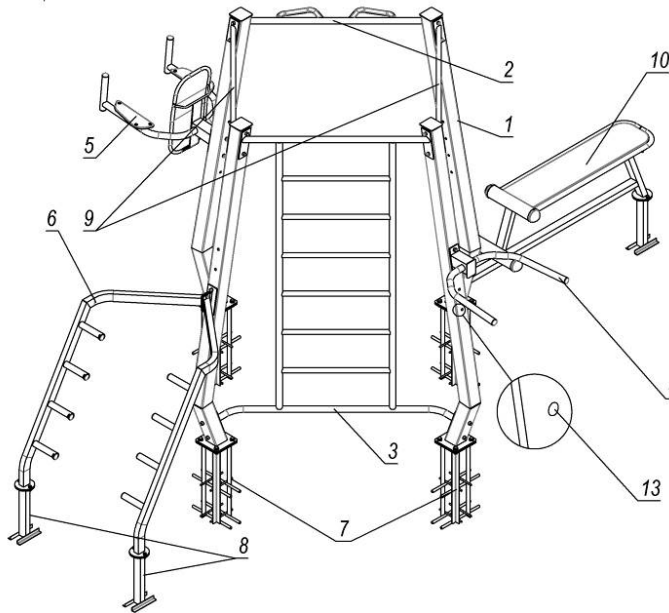

Pos.	Name	Weight, kg	Q-ty
1	Rack 2.42 m	32	4
2	Canopy "Horizontal bar with handles"	9	1
3	Canopy "Wall bar"	31	1
4	Canopy "Beams"	6	1
5	Canopy "Arm press"	19	1
6	Canopy "Handrail"	24	1
7	Embedment 600mm assembly	9	4
8	Embedment 400mm assembly	2	3
9	Canopy "Horizontal bar 1.2 m"	5	2
10	Canopy "Press"	52	1
11	Cap S17		20
12	Cap S17	2	20
13	Plug ZDO 15x12 (for tech. holes)		24
14	Bolt M10x120 GOST 7798		12
15	Bolt M10x130 GOST 7798		8
16	Nut M10 DIN985		20
17	Washer 10 GOST11371		40

SM801.3 – Sports complex Workout

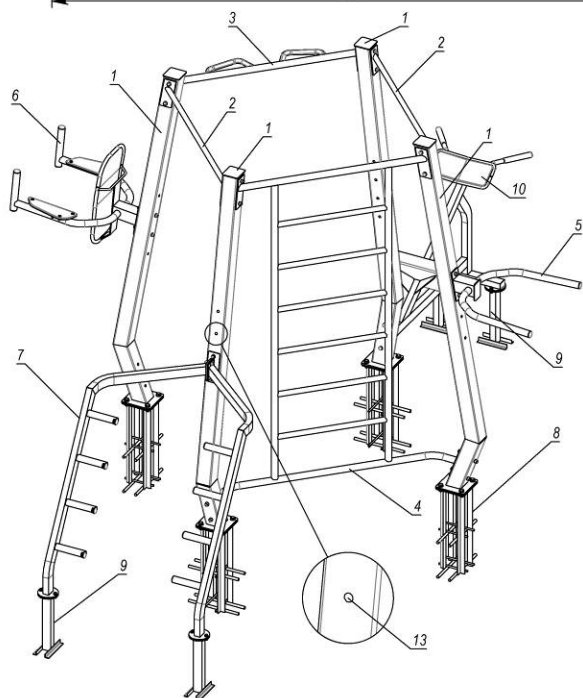
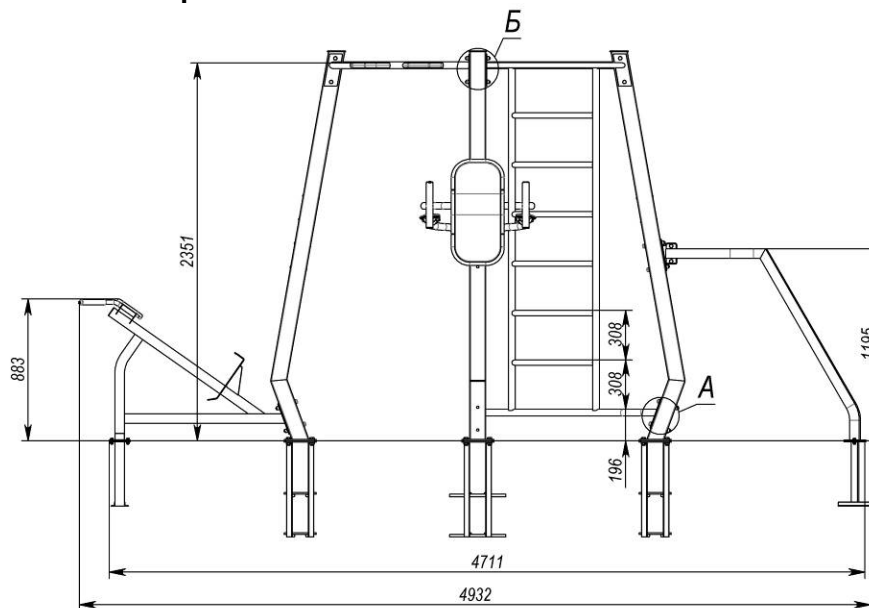
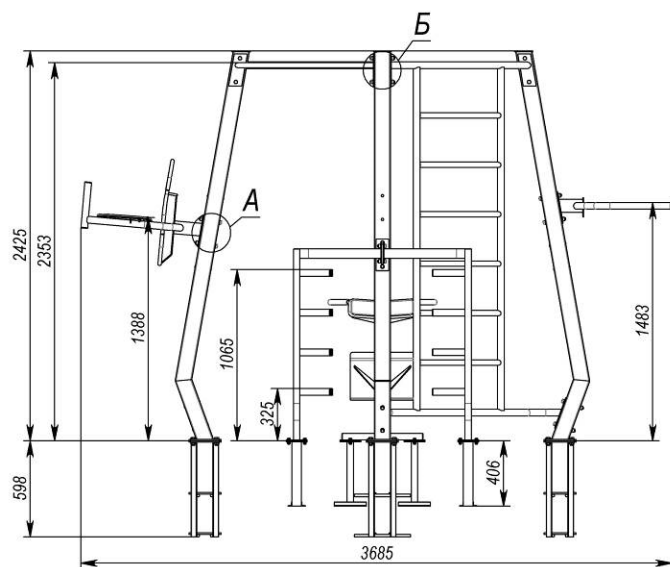

A (1 : 4)

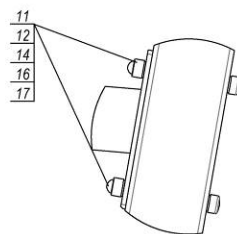

Б (1 : 4)

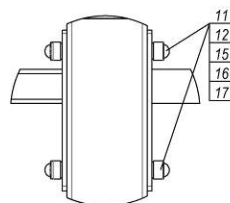

Pos.	Name	Weight, kg	Q-ty
1	Rack 2.42 m	32	4
2	Canopy "Horizontal bar 1.2 m"	5	2
3	Canopy "Horizontal bar with handles"	9	1
4	Canopy "Wall bar"	31	1
5	Canopy "Beams"	6	1
6	Canopy "Arm press"	19	1
7	Canopy "Handrail"	24	1
8	Embedment 600mm assembly	9	4
9	Embedment 400mm assembly	2	4
10	Canopy "Hyperextension"	26	1
11	Cap f17		20
12	Cap S17		20
13	Plug ZDO 15x12		24
14	Bolt M10x120 GOST 7798		12
15	Bolt M10x130 GOST 7798		8
16	Nut M10 DIN985		20
17	Washer 10 GOST11371		40

SM801.4 – Sports complex Workout

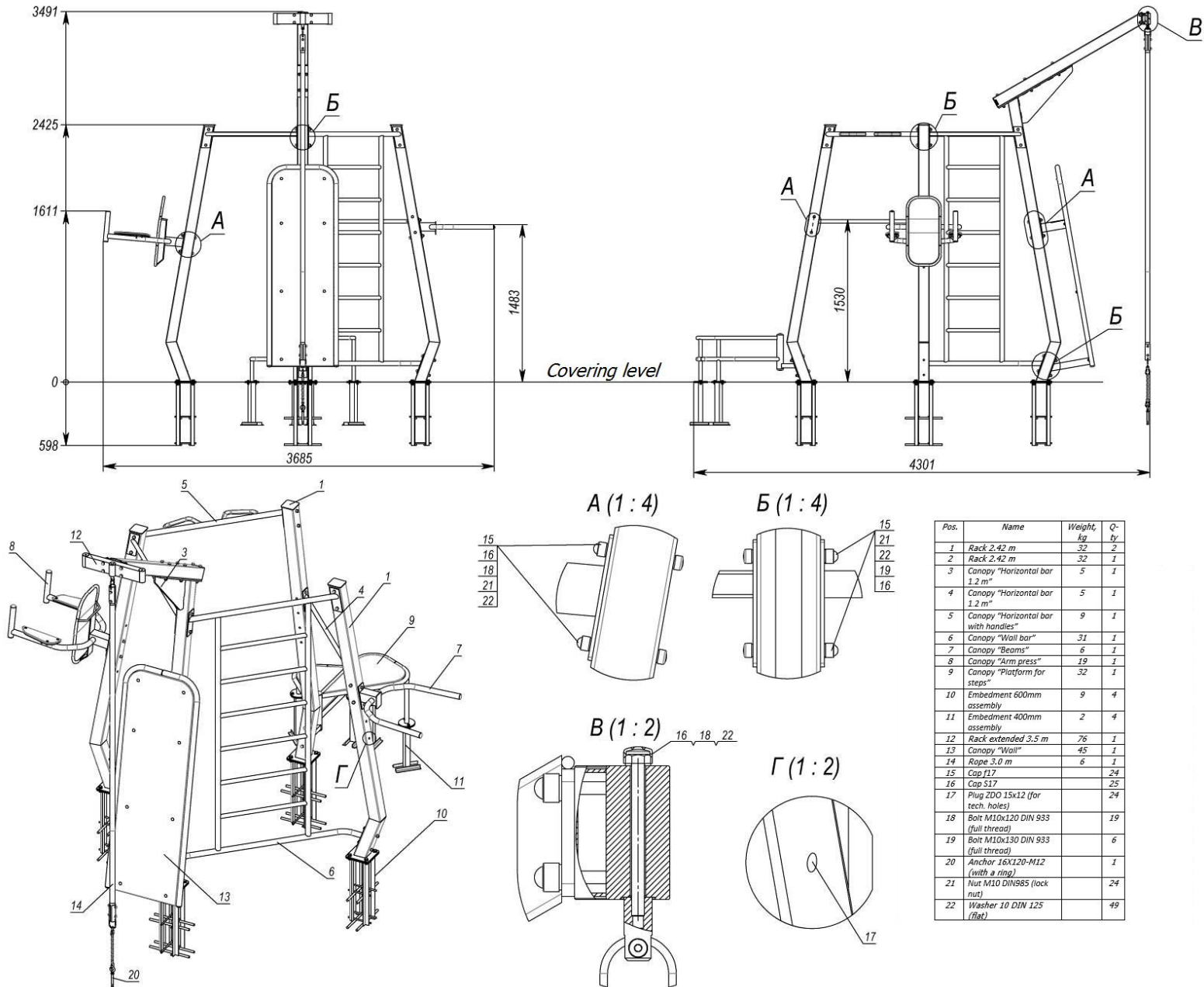

SM802 – Sports complex Workout

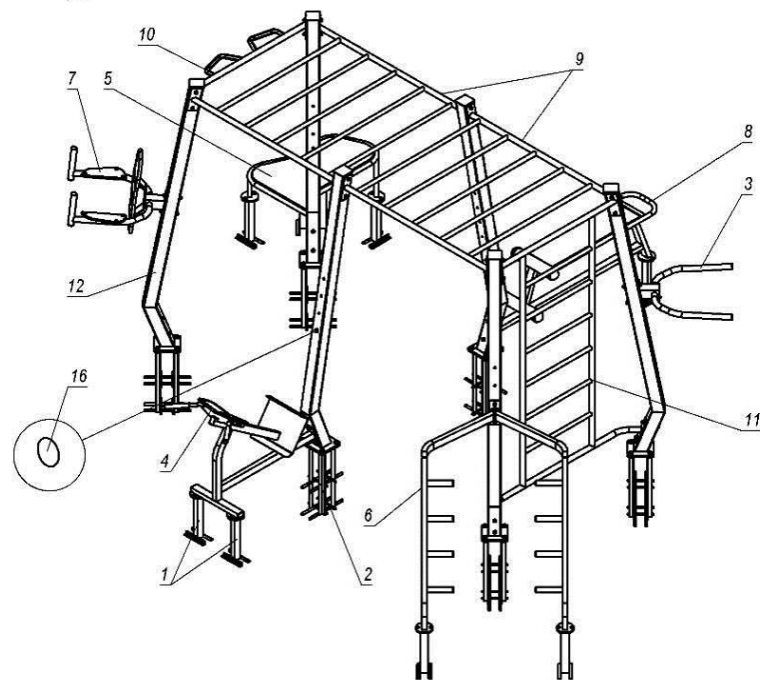
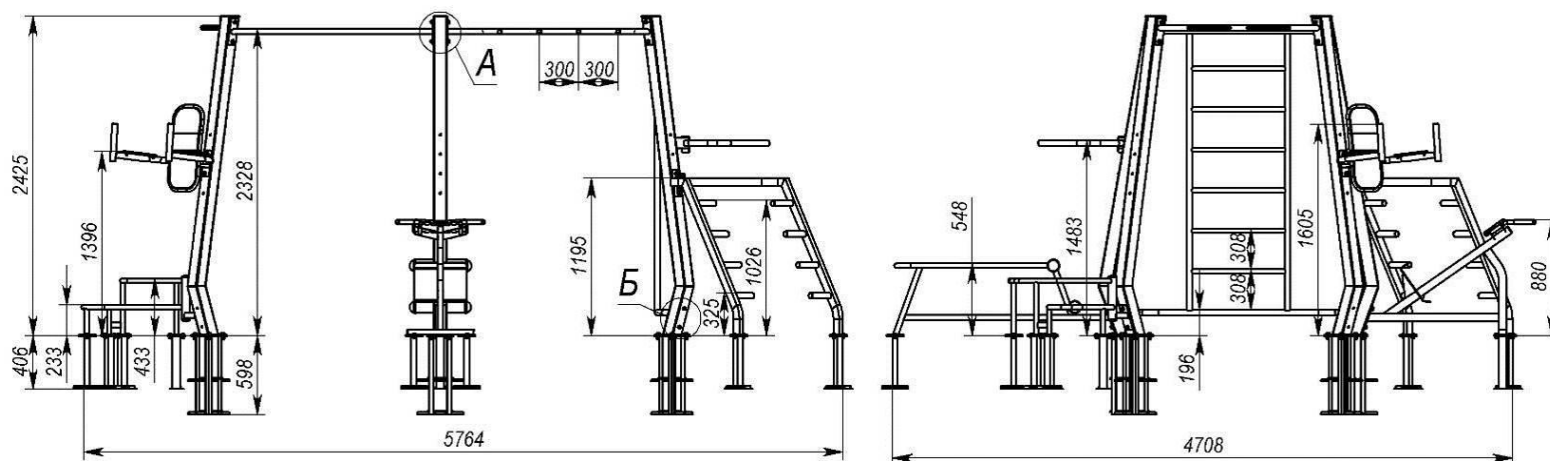

A (1 : 10)

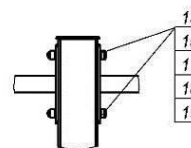

B (1 : 10)

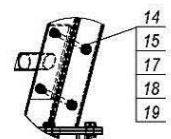

Pos.	Name	Weight, kg	Q-ty	Note
1	Embedment 400mm assembly	2.3	9	
2	Embedment 600mm assembly	9.3	6	
3	Canopy "Beams"	6.2	1	
4	Canopy "Hyperextension"	25.9	1	
5	Canopy "Platform for steps"	32.3	1	
6	Canopy "Handrail"	23.5	1	
7	Canopy "Arm press"	18.3	1	
8	Canopy "Press"	47.5	1	
9	Canopy "Monkey bar"	25.1	2	
10	Canopy "Horizontal bar with handles"	9.9	1	
11	Canopy "Wall bar"	31.3	1	
12	Rack 2.6 m	31.8	6	
13	Bolt M10x130 GOST 7798		12	
14	Bolt M10x120 GOST 7798		16	
15	Nut M10 DIN985		28	
16	Plug ZDO 15x12		40	
17	Cap S17	1.83	28	
18	Cap f17		28	
19	Washer 10 GOST11371		56	

SM802.1 – Sports complex Workout

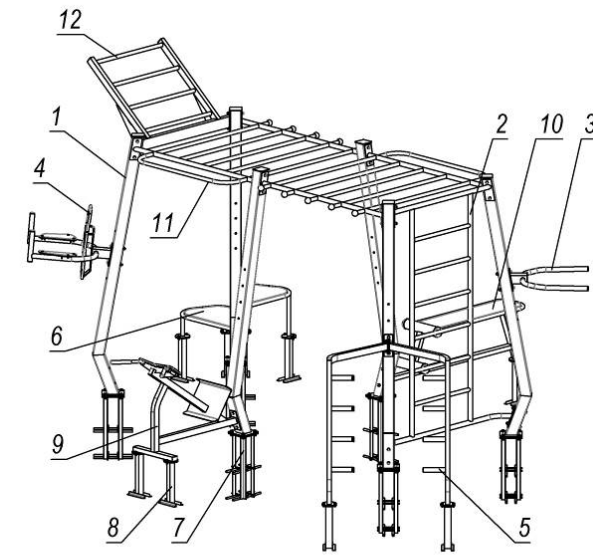
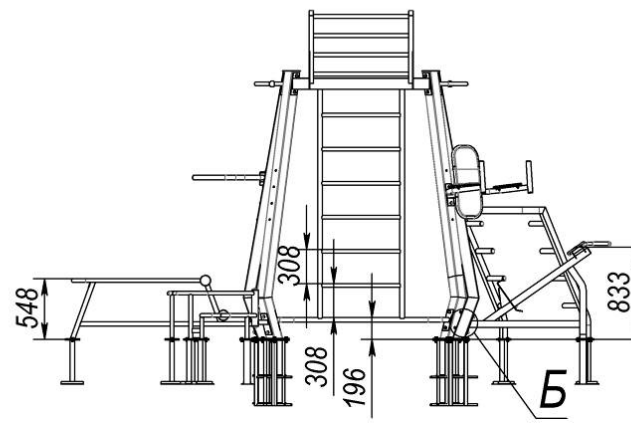
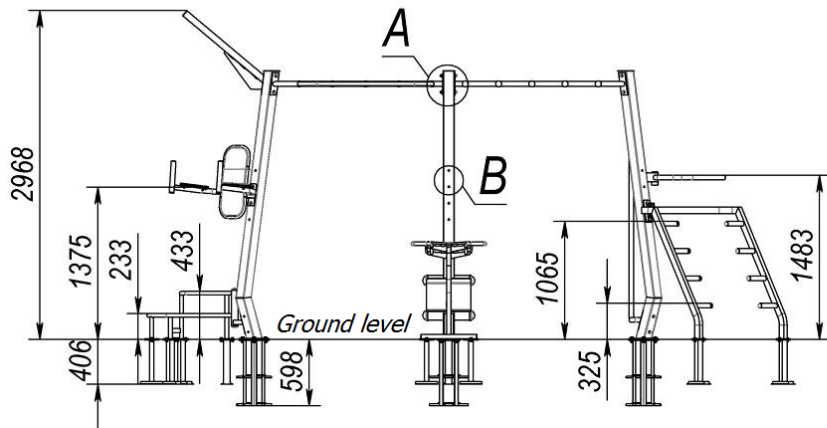

Б (1 : 10)

Б (1 : 10)

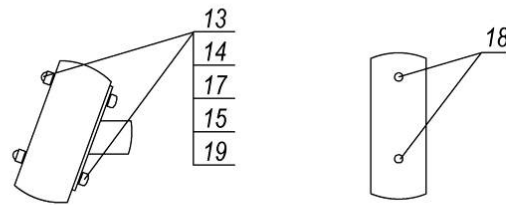

А (1 : 10)

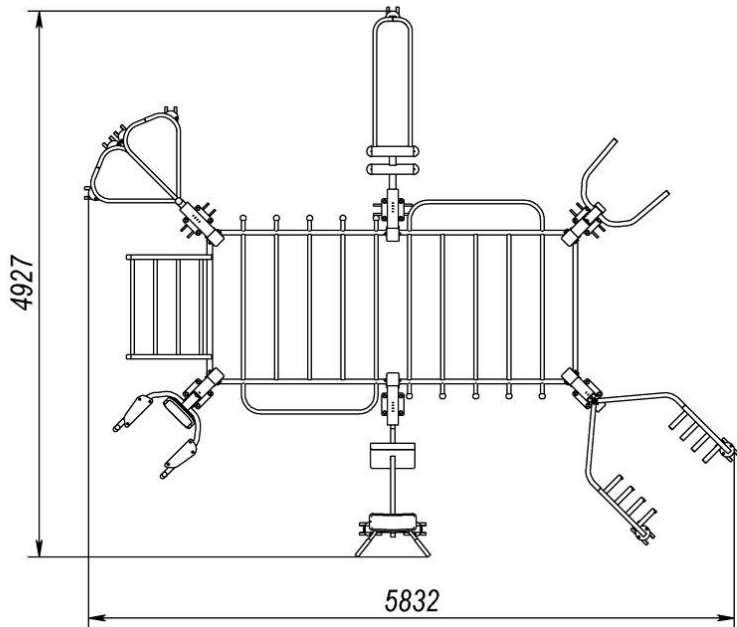
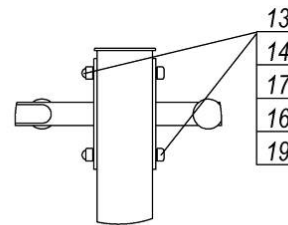

Pos.	Name	Weight, kg	Q-ty
1	Rack 2.42 m	32	6
2	Canopy "Wall bar"	31	1
3	Canopy "Beams"	6	1
4	Canopy "Arm press"	19	1
5	Canopy "Handrail"	23	1
6	Canopy "Platform for steps"	32	1
7	Embedment 600mm assembly	9	6
8	Embedment 400mm assembly	2	9
9	Canopy "Hyperextension"	26	1
10	Canopy "Press"	52	1
11	Monkey bar	32	2
12	Canopy "Horizontal bar-ladder"	26	1
13	Cap f17		28
14	Cap S17		28
15	Bolt M10x120 GOST 7798	2	16
16	Bolt M10x130 GOST 7798		12
17	Nut M10 DIN985		28
18	Plug ZDO 15x12 (for tech. holes)		40
19	Washer 10 GOST11371		56

SM803 – Sports complex Workout

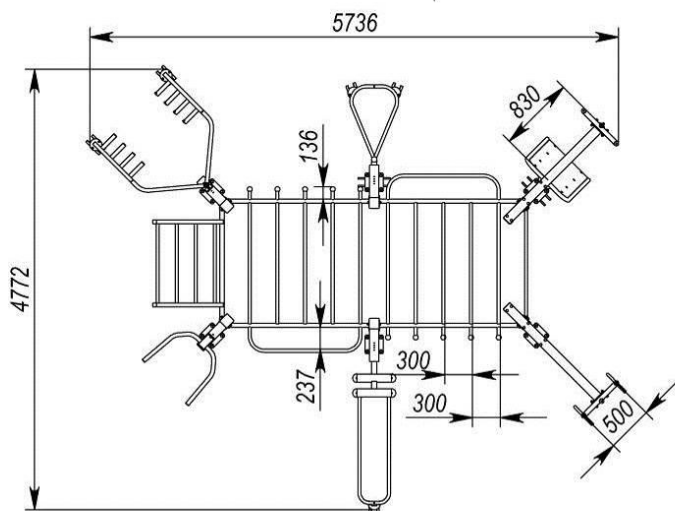
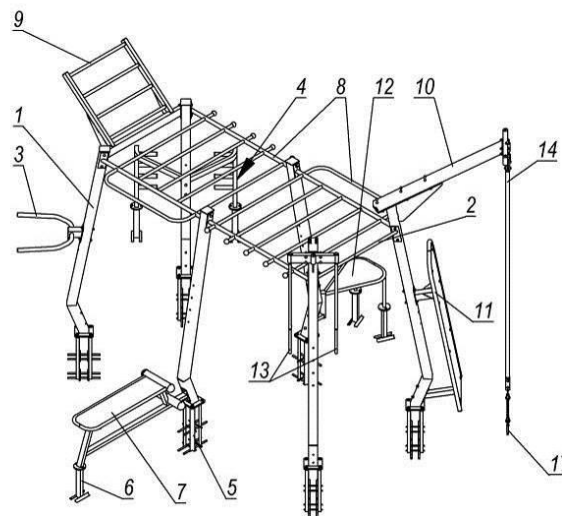
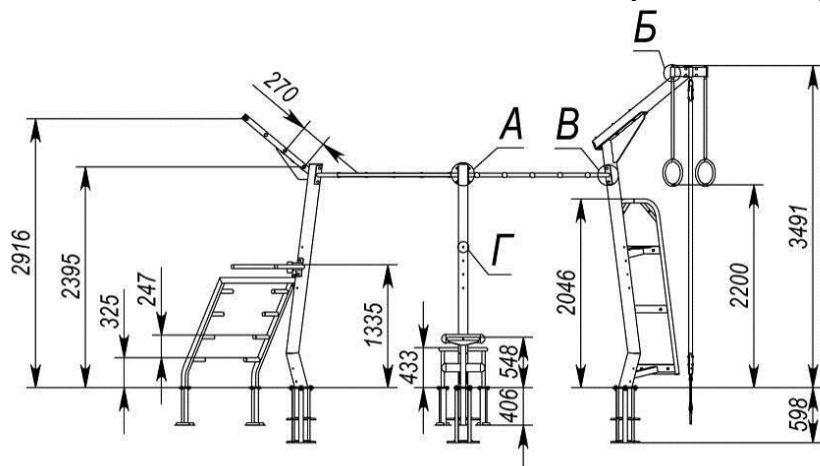

A (1 : 10)

Б (1 : 5)

В (1 : 10)

Г (1 : 5)

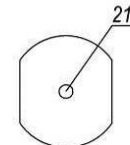
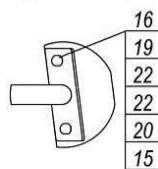
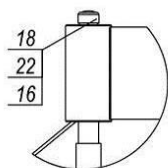
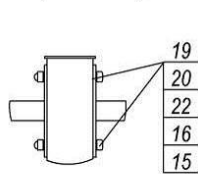

Pos.	Name	Weight, kg	Q-ty
1	Rack 2.42 m	32	4
2	Canopy "Horizontal bar 1.2 m"	5	1
3	Canopy "Beams"	6	1
4	Canopy "Handrail"	24	1
5	Embedment 600mm assembly	9	6
6	Embedment 400mm assembly	2	5
7	Canopy "Press"	52	1
8	Monkey bar	32	2
9	Canopy "Horizontal bar-ladder"	26	1
10	Rack extended 3.5 m	76	2
11	Canopy "Wall"	45	1
12	Canopy "Platform for steps"	18	1
13	Canopy "Gymnastic hoop"	2	2
14	Rope 3.0m	6	1
15	Cap f17		24
16	Cap S17		27
17	Anchor 16X120-M12 (with a ring)		1
18	Bolt M10x120 GOST 7798		15
19	Bolt M10x130 GOST 7798		12
20	Nut M10 DIN985		24
21	Plug ZDO 15x12 (for tech. holes)		54
22	Washer 10 GOST11371		51

Appendix B

Marking the area for concreting the complex SM 800

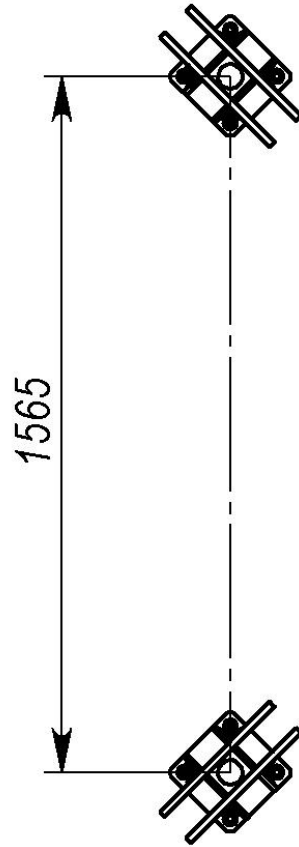

Marking the area for concreting the complex SM 801

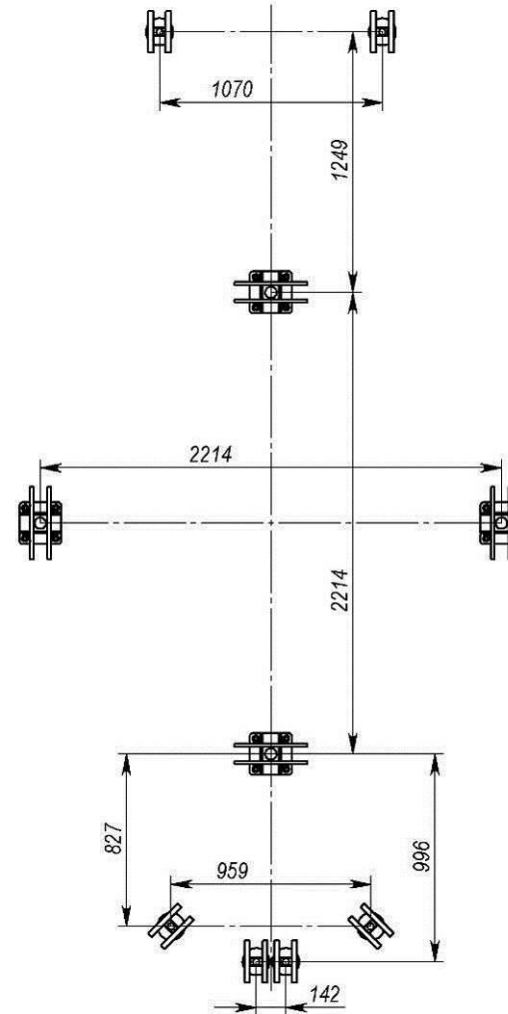

Marking the area for concreting the complex SM 801.1

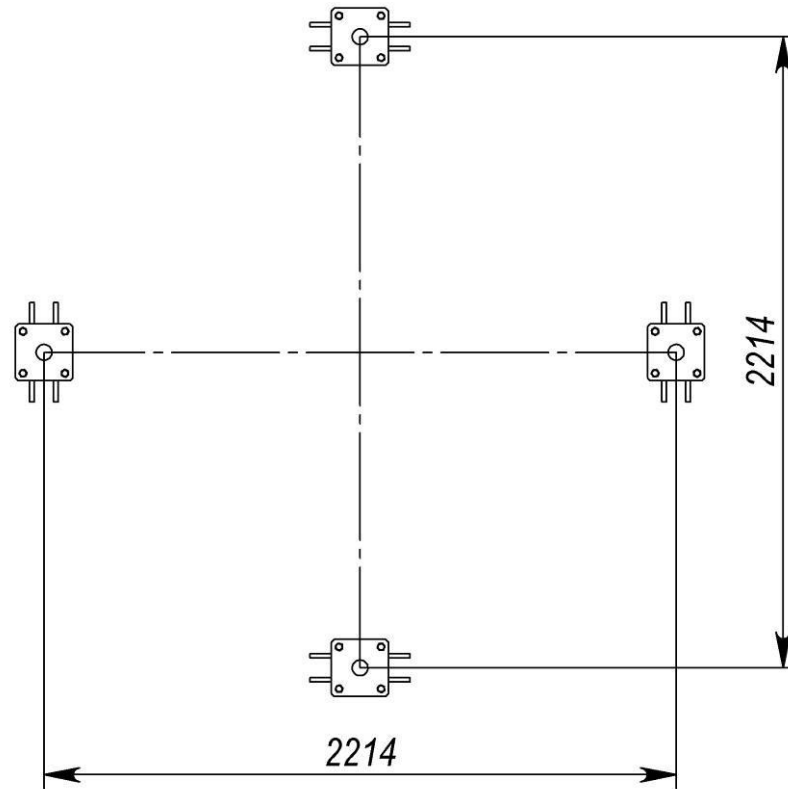

Marking the area for concreting the complex SM 801.2

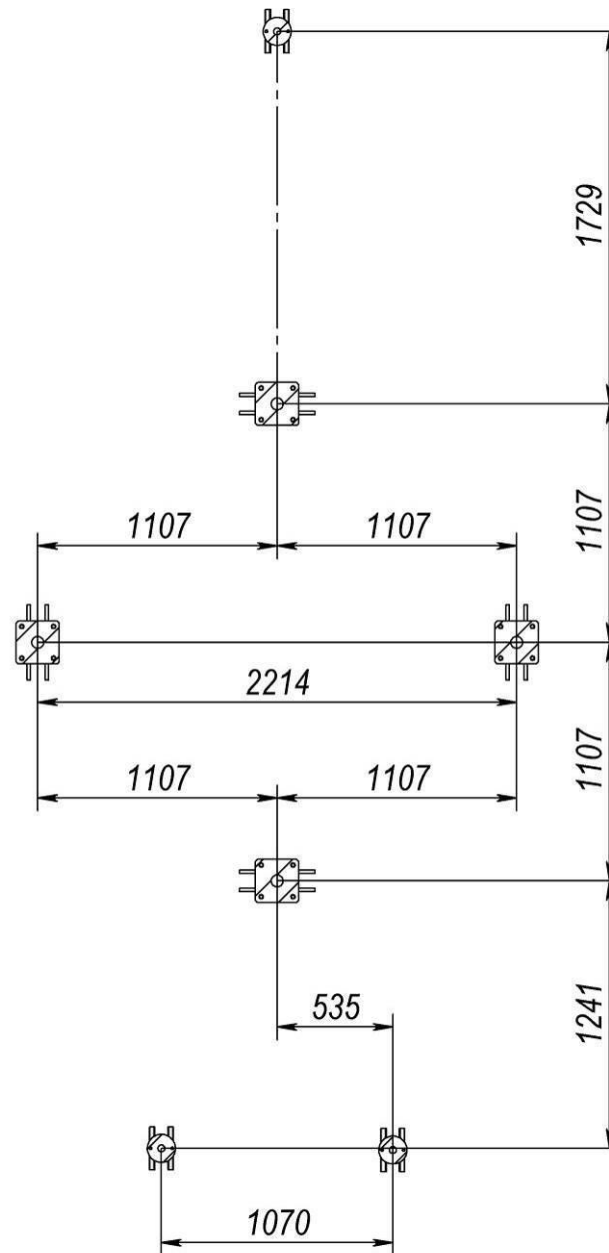

Marking the area for concreting the complex SM 801.3

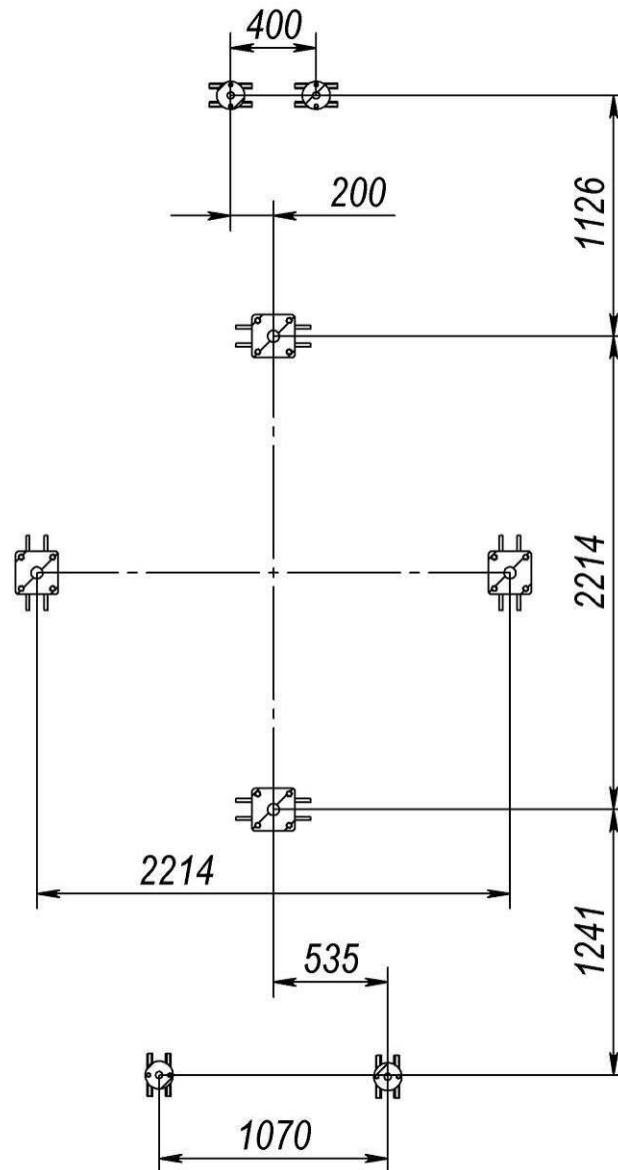

Marking the area for concreting the complex SM 801.4

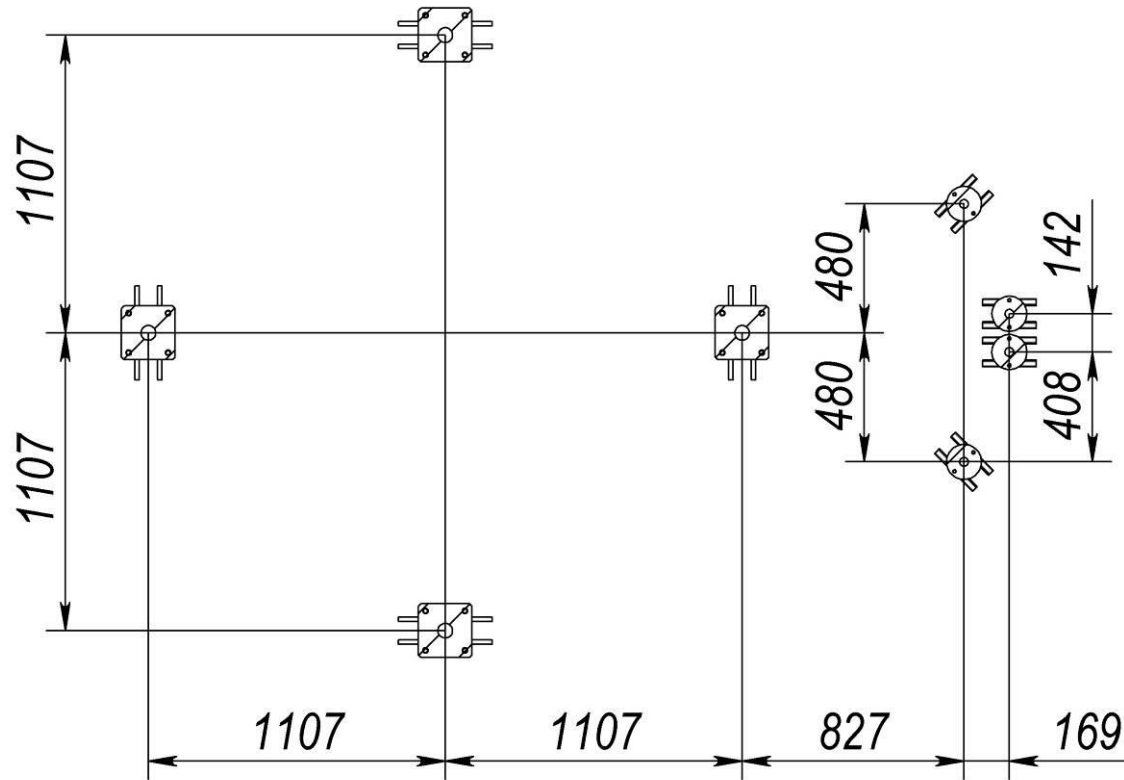

Marking the area for concreting the complex SM 802

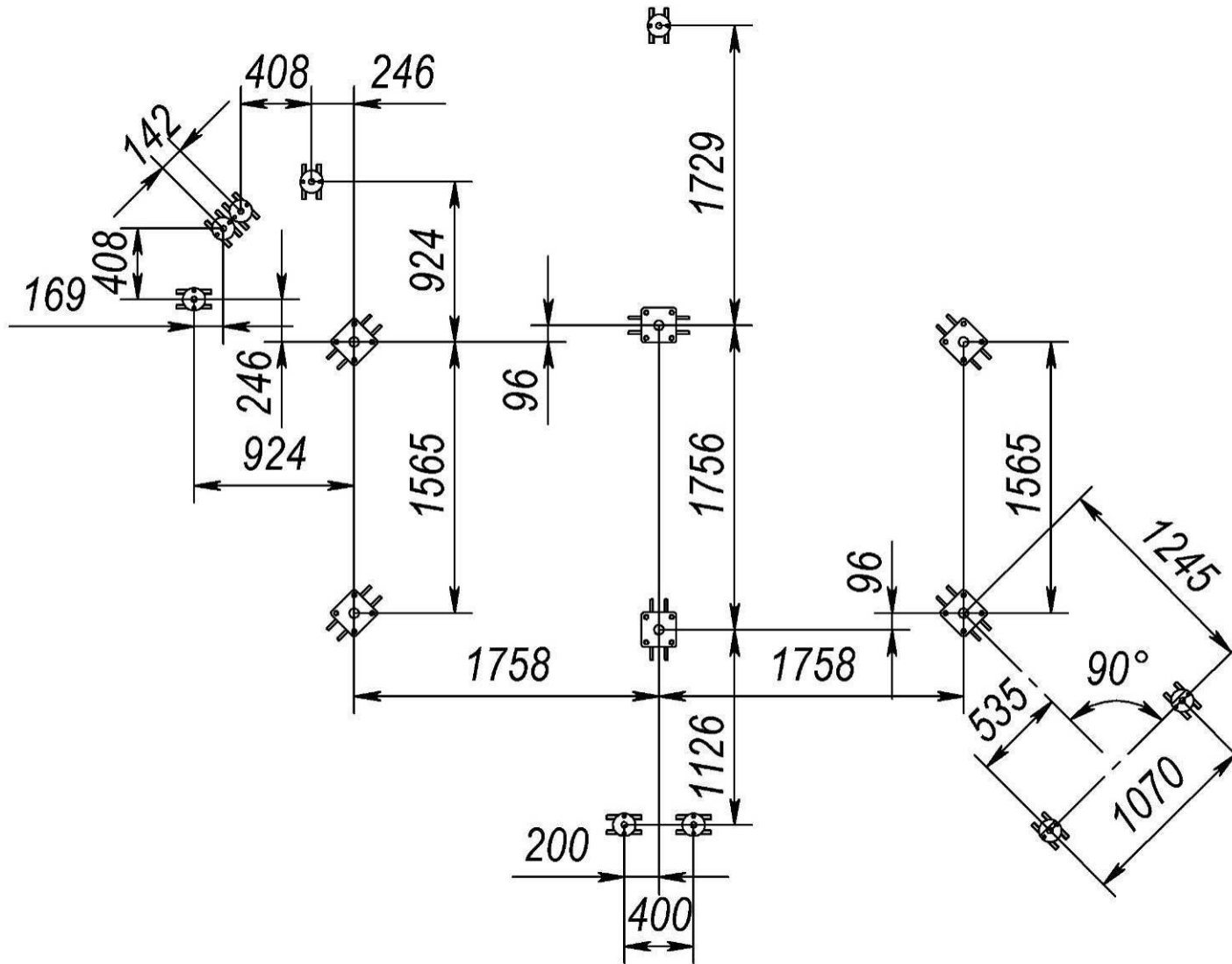

Marking the area for concreting the complex SM 802.1

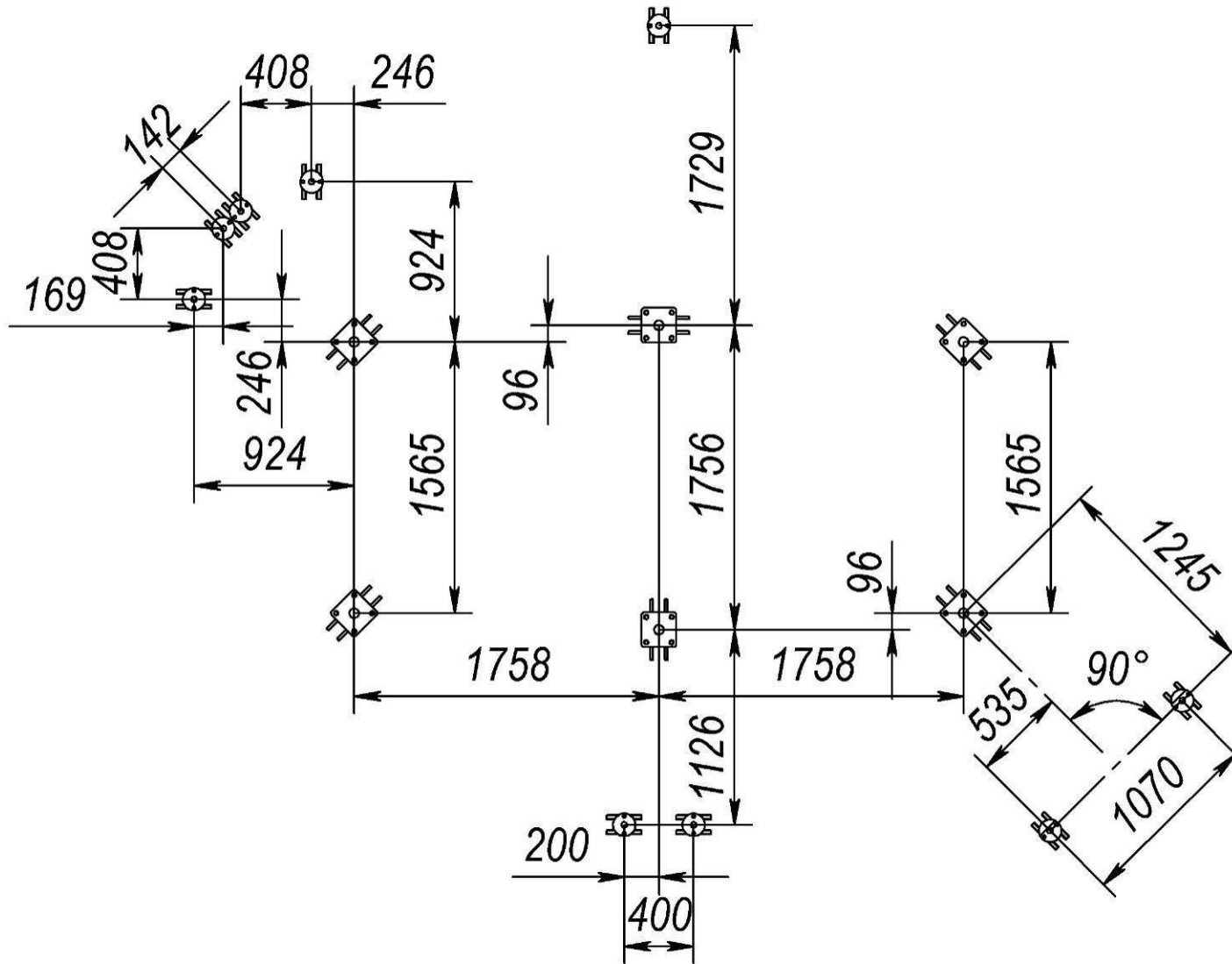

Marking the area for concreting the complex SM 803

