

# interatletika™

PRODUCTION AND SALE OF SPORTS GOODS

Customer support:

+38 095 273 81 53

[play.interatletika.com](http://play.interatletika.com)

## DATA SHEET

Playground complex «Big City-4» TE934

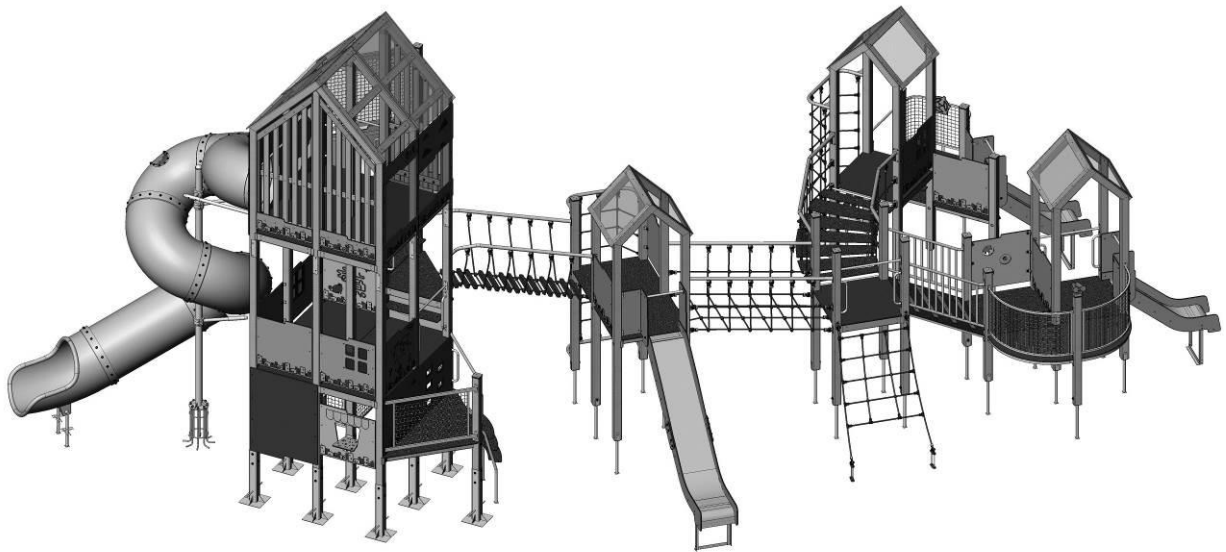



## 1. GENERAL INFORMATION

**Purpose and content of this document.** This document contains general description of the equipment, information on installation, intended use, maintenance, repair and manufacturer's warranty.

**Distribution of this document for product modifications.** Manufacturer can make changes to the product design to improve its performance, change the design, etc. This document may not contain a description of such changes, but applies to the following modified products.

## 2. ASSEMBLING AND INSTALLATION OF THE PRODUCT

**Tools and accessories.** The product does not include the tools required for installation.

**Procedure of assembling and installing the product.**

- 1) Mark the area according to the foundation location scheme.
- 2) Make the digs for installation of the embedded parts and the attachments. The depth of these digs leveled by deepening or adding the gravel.
- 3) Assemble and install the equipment in accordance with the assembly schemes - chapter 7.
- 4) To concrete the embedded parts and support constructions of the attachment elements. During installation of equipment on a sand soil, overall sizes of the digs must be increased by 15-20%.

To avoid cracking of the wood, it is necessary to drill the holes with diameter 0,6..0,7 of the start diameter and depth up to 0,8 of it's length for the screws with diameter more than 4 mm.

**WARNING! The presence and participation of the children in the process of installation of the equipment is not allowed.**

## 3. PRODUCT USE

Do not use the product until it has been fully and completely installed.

Do not use the product by users of a different age and weight category.

Before using the product, clear the safety zone of unnecessary objects that may cause harm to the user (debris, tools left after assembly and installation, etc.).

Do not use the product in adverse weather conditions (ice, snow, rain, hail, strong winds, etc.), which may cause injury to the user.

## 4. PRODUCT MAINTENANCE

You have purchased high-quality and reliable equipment. In the process of its production, the requirements of regulatory and technical documents of Ukraine, the CIS countries and the European Union regulating the production of children's gaming equipment were taken into account. However, it should not be forgotten that when operating any technical product, certain rules and requirements must be followed. Despite the fact that our product is of high quality and reliability, this rule applies to it in full. You should be aware that the implementation of the following rules and recommendations for product maintenance is aimed at ensuring that your child, the child of your friends or acquaintances is safe and no unforeseen factors threaten his health, life.

Remember that the operation of the product is accompanied by the influence of various negative factors on it, a complete list of which cannot be predicted. Among them, an important place is occupied by natural factors and factors caused by human influence on equipment. As a rule, their action initially leads to disruptions in the appearance of the product. Thus, under the influence of factors caused by the exploitation of a person, there may be damage to the integrity of the paint coating of parts made of wood, in the form of scuffs, chips, incisions, and when exposed to parts made of metal, damage to the paint coating in the form of nicks, chips, abrasion, etc. This leads to the emergence and development of defects that can be the cause of the destruction of the product. The product is particularly dangerous if it is used for other than its intended purpose, if the permissible loads are exceeded, or if vandalism occurs, as these factors can cause irreversible changes in the structure of the material from which the product is made, leading to destruction.

The maintenance of the product implies, first of all, the responsibility of the user to comply with all recommendations provided in this document, starting with a daily inspection of the external condition of the product before operation.

Daily inspection of the product is a very important procedure. With its help, you can timely detect any changes in the appearance of the product (deformation of individual parts, deformation of the structure as a whole or part of it, damage to parts, cracks of welds, as well as the absence of fastening of parts of the product, etc.).

Before using the product, check its operability, absence of damage, dirt on the product, sharp edges, reliability of fixing the structure, absence of unnecessary objects on the surface of the site. If the product is damaged, fully or partially inoperable, or has any other defects, do not use it.

During operation it is also necessary to inspect the condition of the product periodically - the current inspection. It includes an external inspection of the product, checking its operability (in the presence of moving elements - the smoothness of the movement of mechanisms, compliance with operating modes, etc.). Current inspection allows you to detect malfunctions caused by the operation of equipment, climatic conditions, acts of vandalism and other factors, until they reach a critical level and the destruction of the product. The current inspection is carried out in order to detect foreign objects that may threaten the user and lead to violations of the functioning of the product. The frequency of the current inspection is set by the owner taking into account the operating conditions. If you do not have sufficient technical knowledge and skills to conduct such inspections, we recommend you to contact the authorized specialists of the manufacturer in order to obtain advice.

Every three months, a scheduled inspection should be carried out, which primarily concerns the foundation part, load-bearing elements and connection nodes of elements (their integrity and degree of deterioration).

The main annual inspection must be carried out annually by authorised specialists of the manufacturer. During the inspection, the technical condition of the equipment shall be assessed for compliance with safety requirements. The degree of deterioration and damage to wooden elements and their ability to withstand the applied loads, damage, corrosion of metal elements and the impact of these factors on the safety of the product are determined. The inspection also helps to identify the impact of repairs, if any, on the safety of the equipment. Based on the results of the inspection, a maintenance procedure is carried out to eliminate the identified discrepancies in the product's operation. This procedure includes assessing the condition of parts and assemblies, replacing worn parts, and restoring the integrity of protective coatings. The results of the inspections, as well as the procedures carried out as a result of the inspection and maintenance of the product must be properly documented in the Registration Journal, which is an integral part of this passport. The owner of the product must keep the acts of maintenance of the product, acts of repair work.

## 5. STORAGE, TRANSPORT AND DISPOSAL INFORMATION

The product is transported in the manufacturer's packaging by any means of transport that ensures its safety and protection from external factors (rain, snow, sunlight, water, high humidity, etc.).

### Information about transportation

Date		Brand, state number of the ca/trailer	Position, full name	Signature
Departure	Arrival			

Before installation, store the product in the original packaging in dry, closed rooms with natural air ventilation.

If it is necessary to transport the product to another location after use, it is recommended to use the manufacturer's packaging.

If long-term storage of the product is required, the following storage rules must be observed (the list of conditions is not complete):

- place the product in a closed dry room with natural ventilation;
- protect the product from external factors (dust, water drops, etc.) with a large plastic bag, leaving space for free air circulation;
- take other measures to preserve the appearance and characteristics of the product during storage.

When removing the product from storage and preparing for installation, follow the next recommendations:

- remove the product from the packaging material (polyethylene, cardboard, other packaging materials);
- remove dust and other contaminants from the surface of the product;
- check completeness and absence of parts damage.

### Storage information

Date		Product storage conditions	Full name	Signature
Putting into storage	Removal from storage			

After the end of the equipment's service life, the buyer independently determines the procedure for its use. If you decide to recycle, contact the seller or specialized organizations.

The equipment does not contain harmful impurities and materials that can harm your health and is not subject to special recycling.

## 6. TECHNICAL DATA AND ASSEMBLY SCHEMES

Length, mm  
Width, mm  
Height, mm  
Weight, kg  
Height of fall, mm  
Age restrictions, years  
Weight limits, kg

**15046**  
**7114**  
**6008**  
**2747**  
**2029**  
**Up to 12**  
**Up to 60**

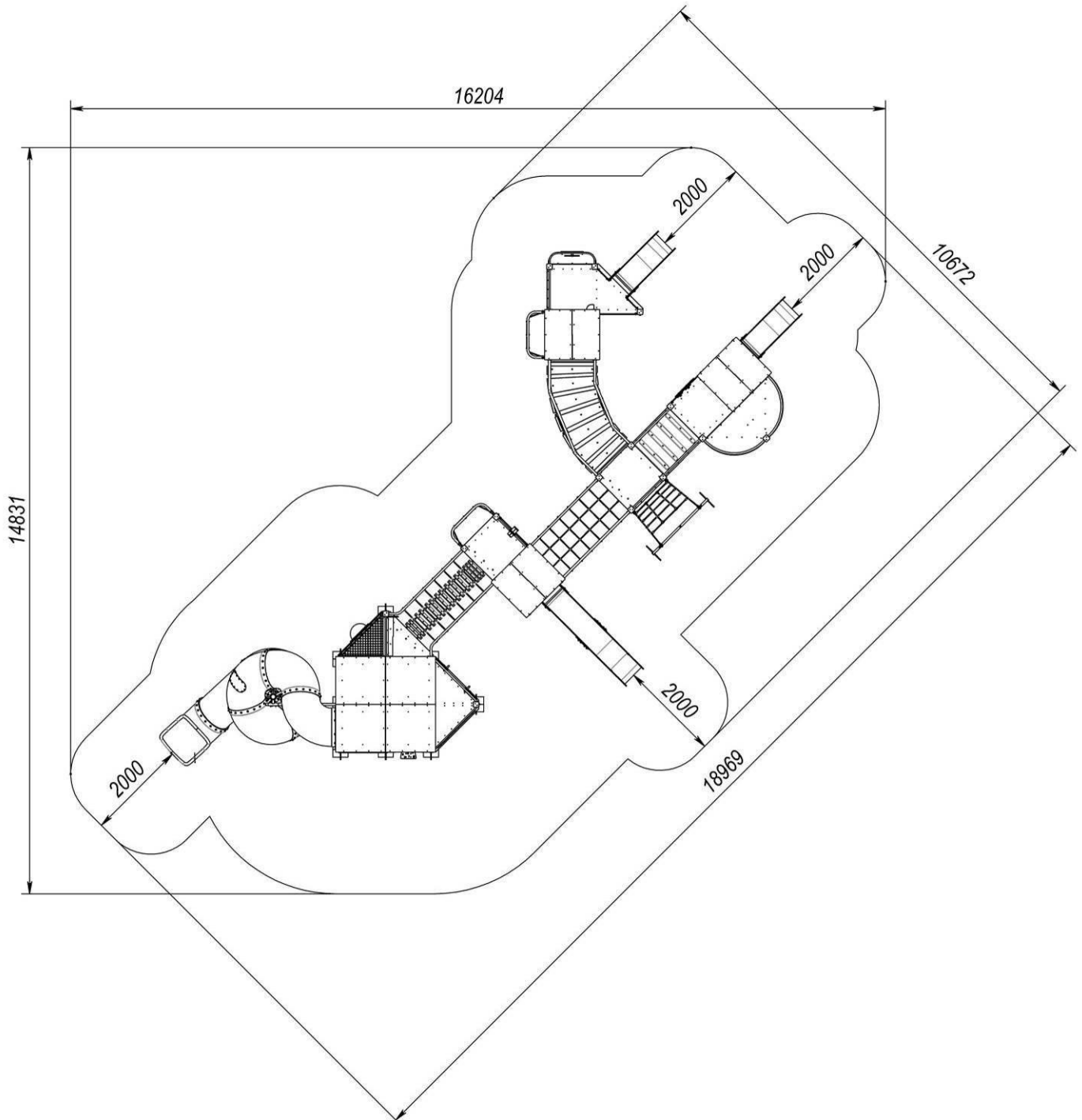

**Picture 1 – Landing zone**



Assembly scheme of the multi-level tower

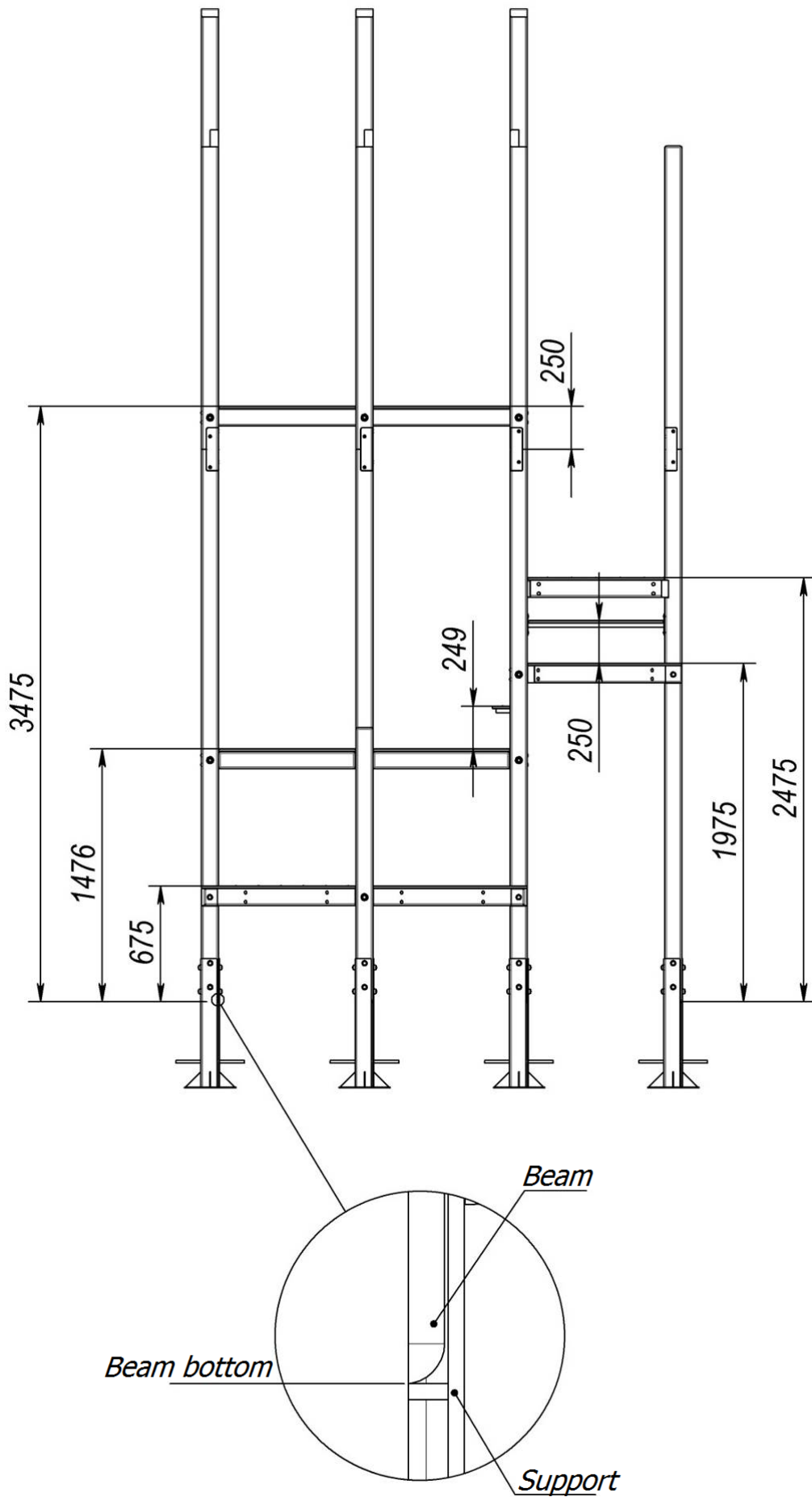

**Picture 3 – Layout of sites**

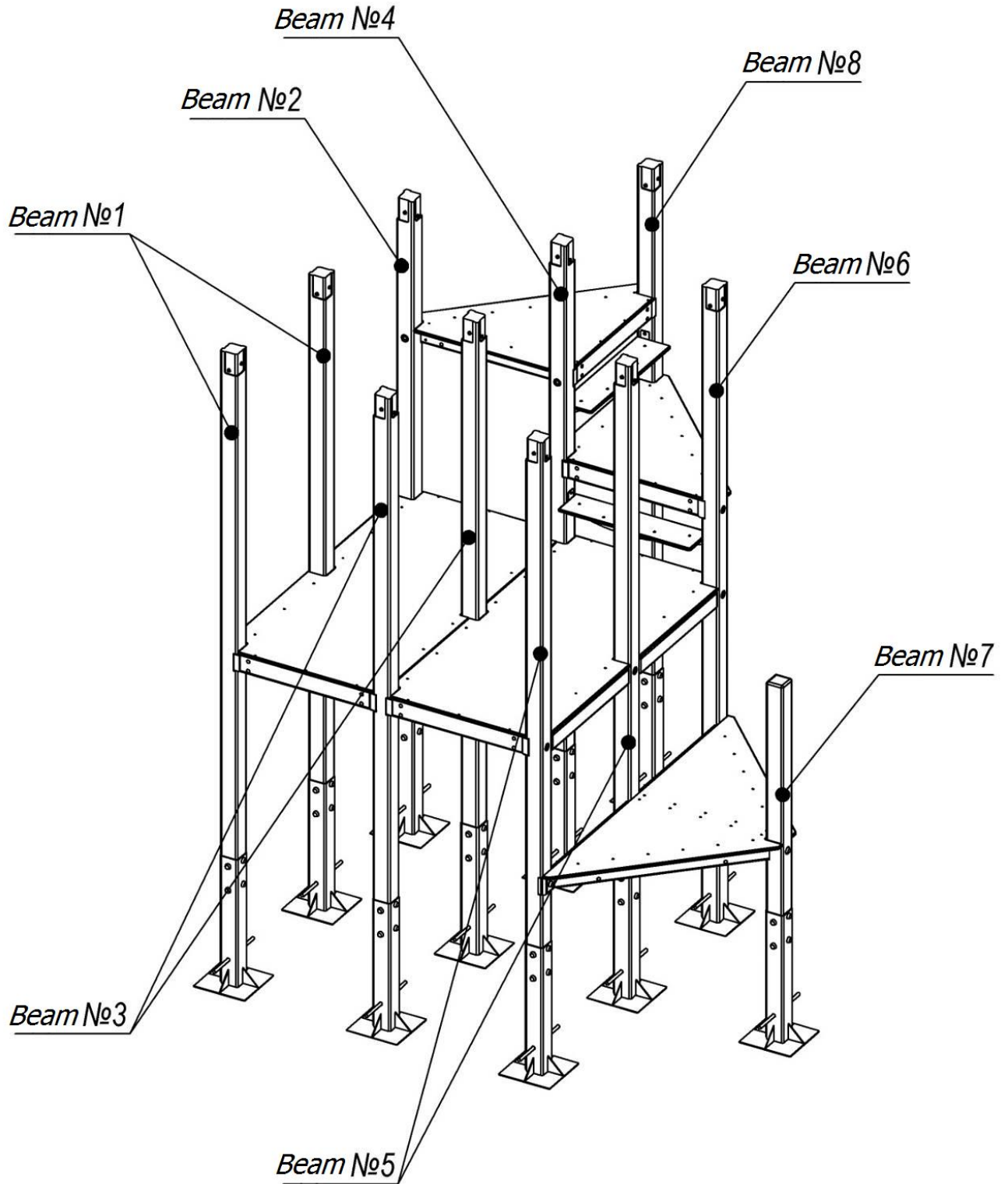

**Picture 4 – Layout of lower level beams**

Beam № 1

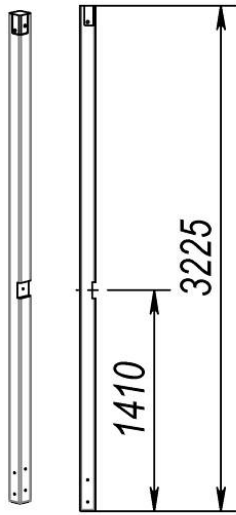

Beam №2

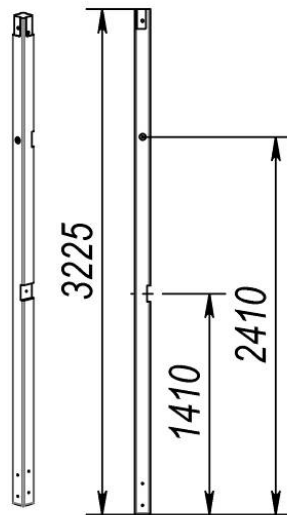

Beam №3

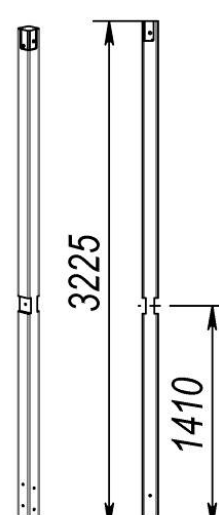

Beam №4

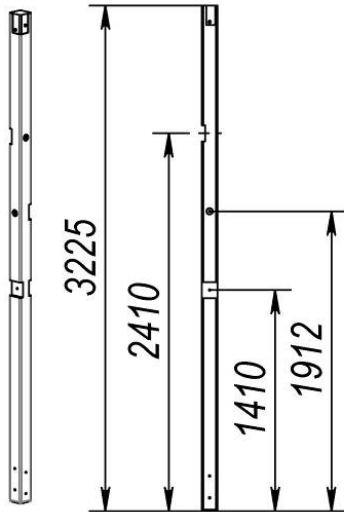

Beam №5

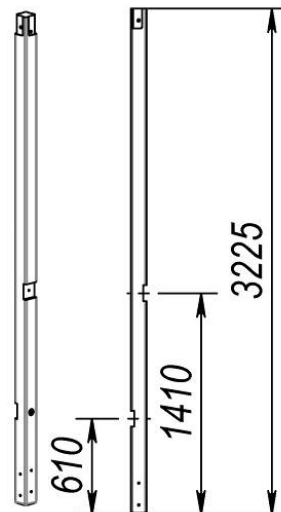

Beam №6

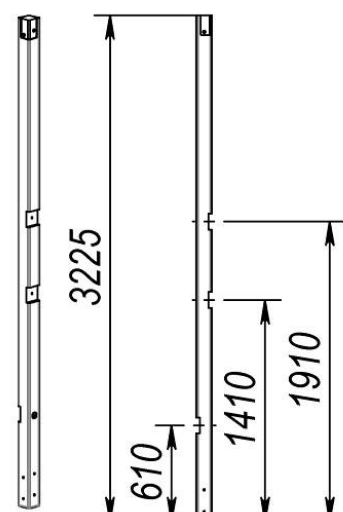

Beam №8

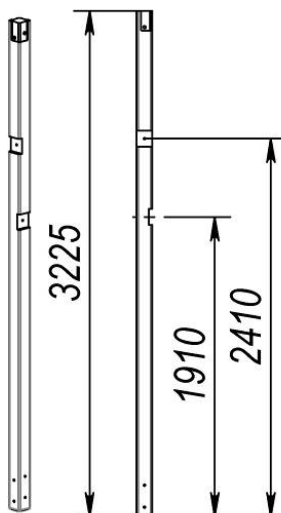

Beam №7

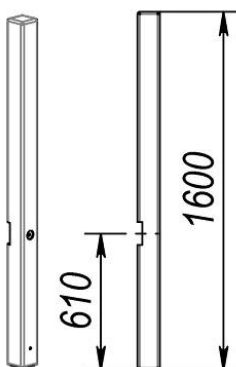

Picture 5 – Beams (1-8)

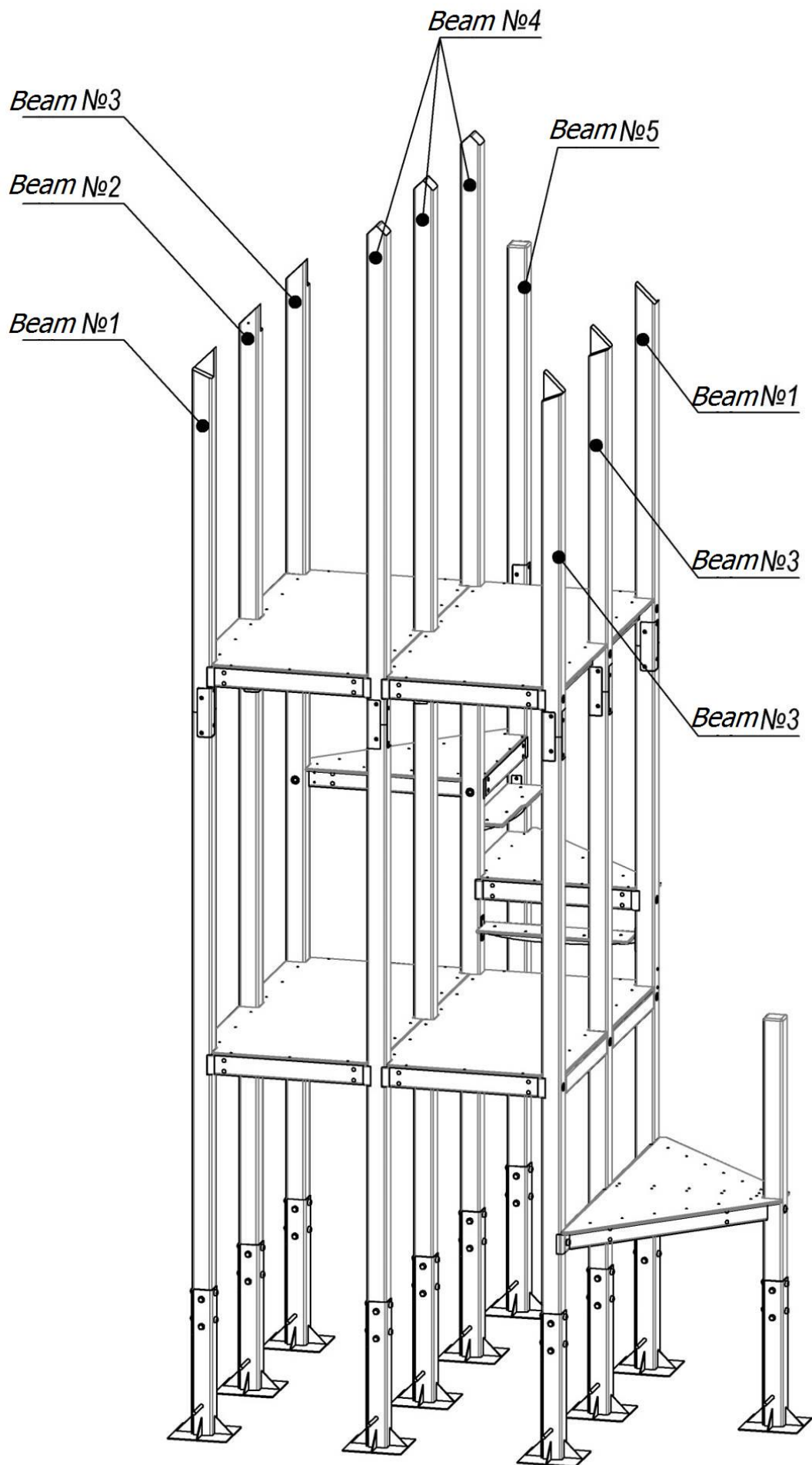

Picture 6 – Layout of upper level beams

*Beam №1*

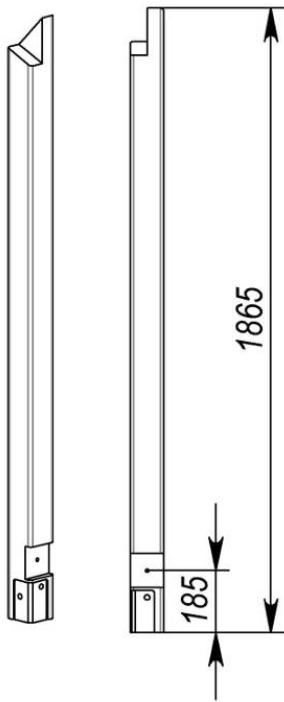

*Beam №2*

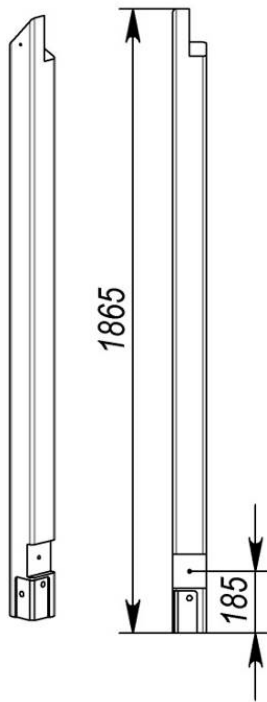

*Beam №3*

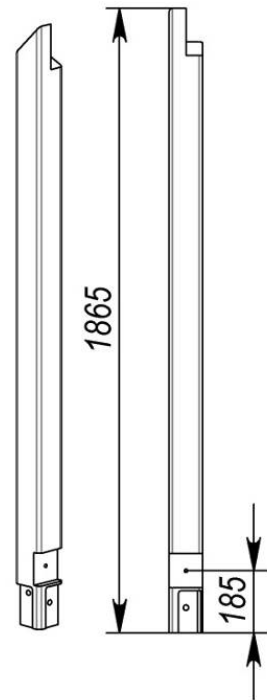

*Beam №4*

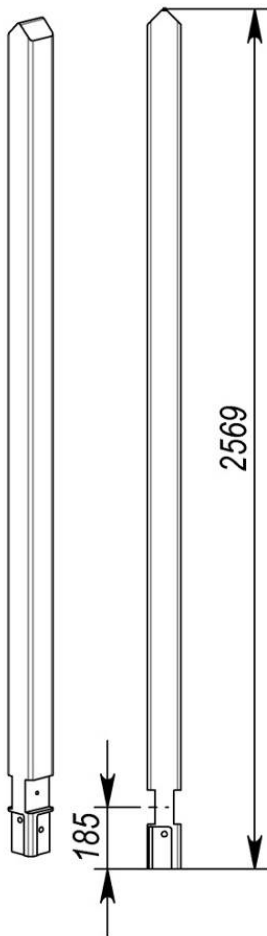

*Beam №5*

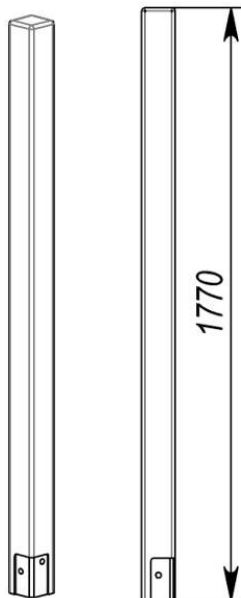

**Picture 7 – Beams (1-5)**

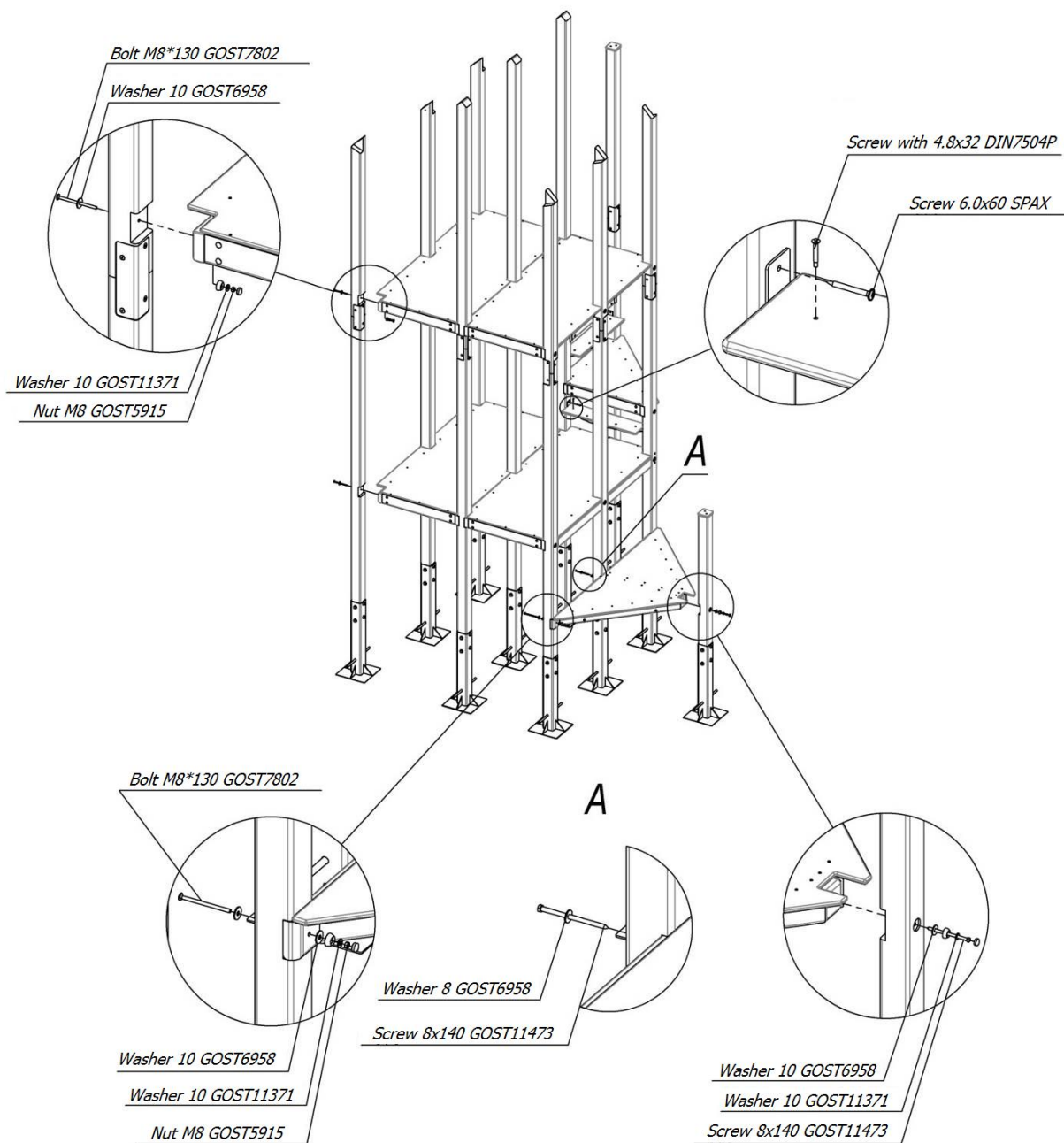

View from below. Connection of middle beams with site

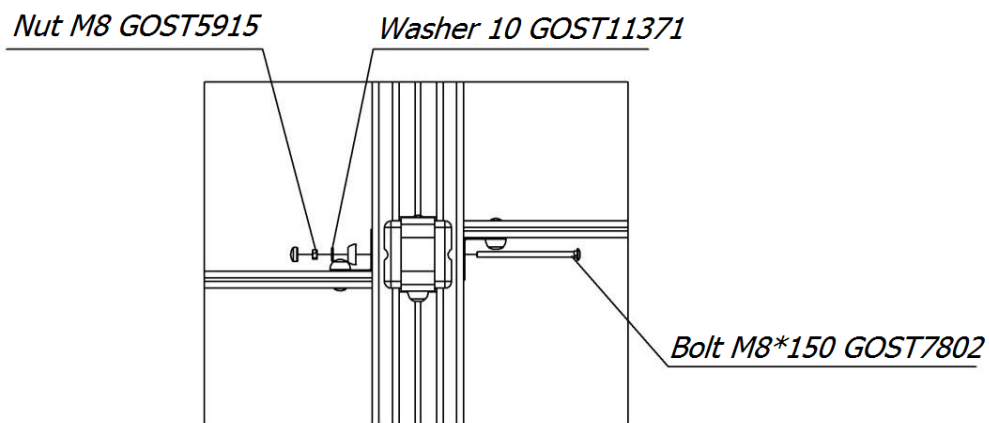

Picture 8 – Assembly scheme of multi-level tower. (Additionally assembly scheme is in the Appendix)

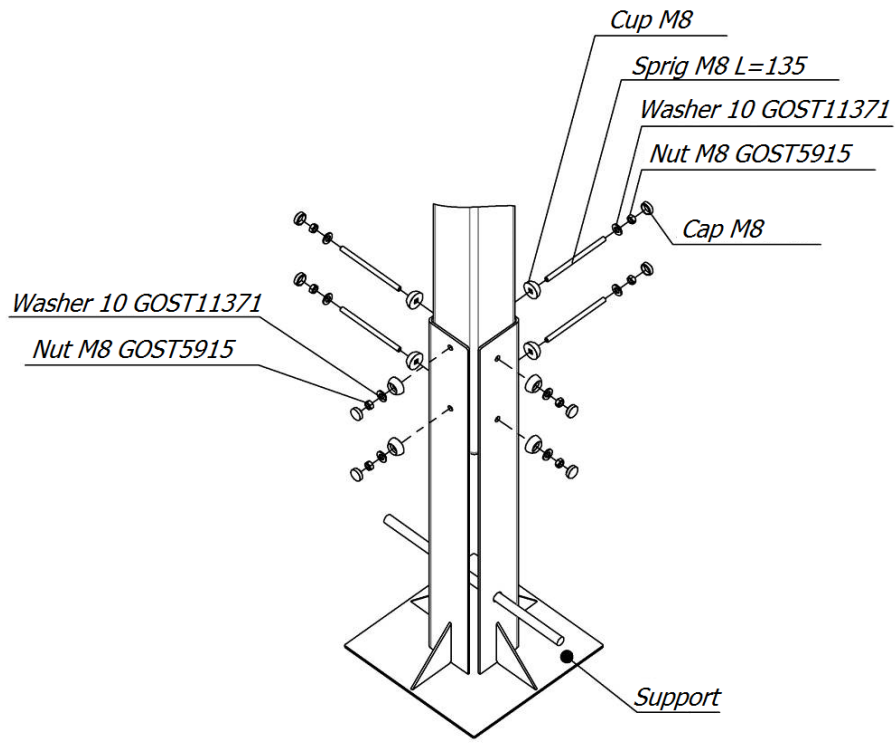

**Picture 9 – Assembly scheme of support with beam**

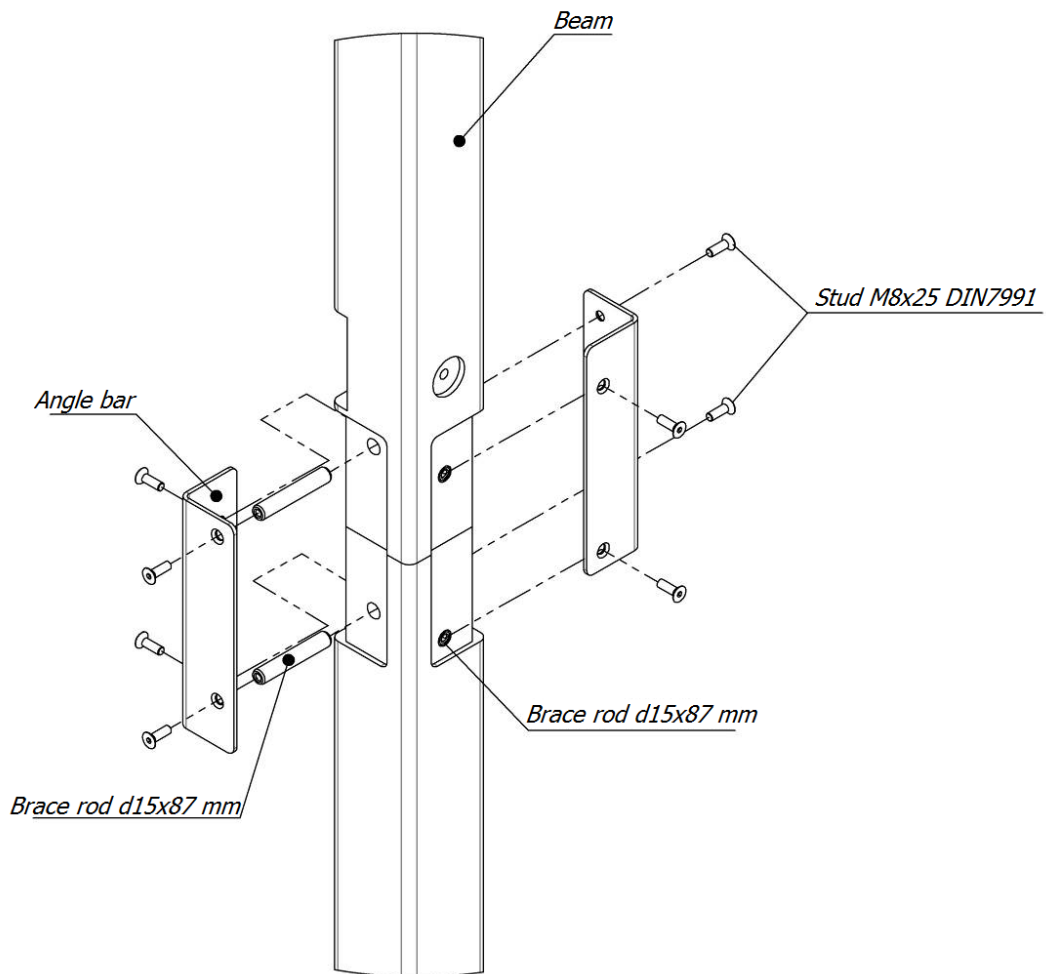

**Picture 10 – Connecting scheme of the two beams**

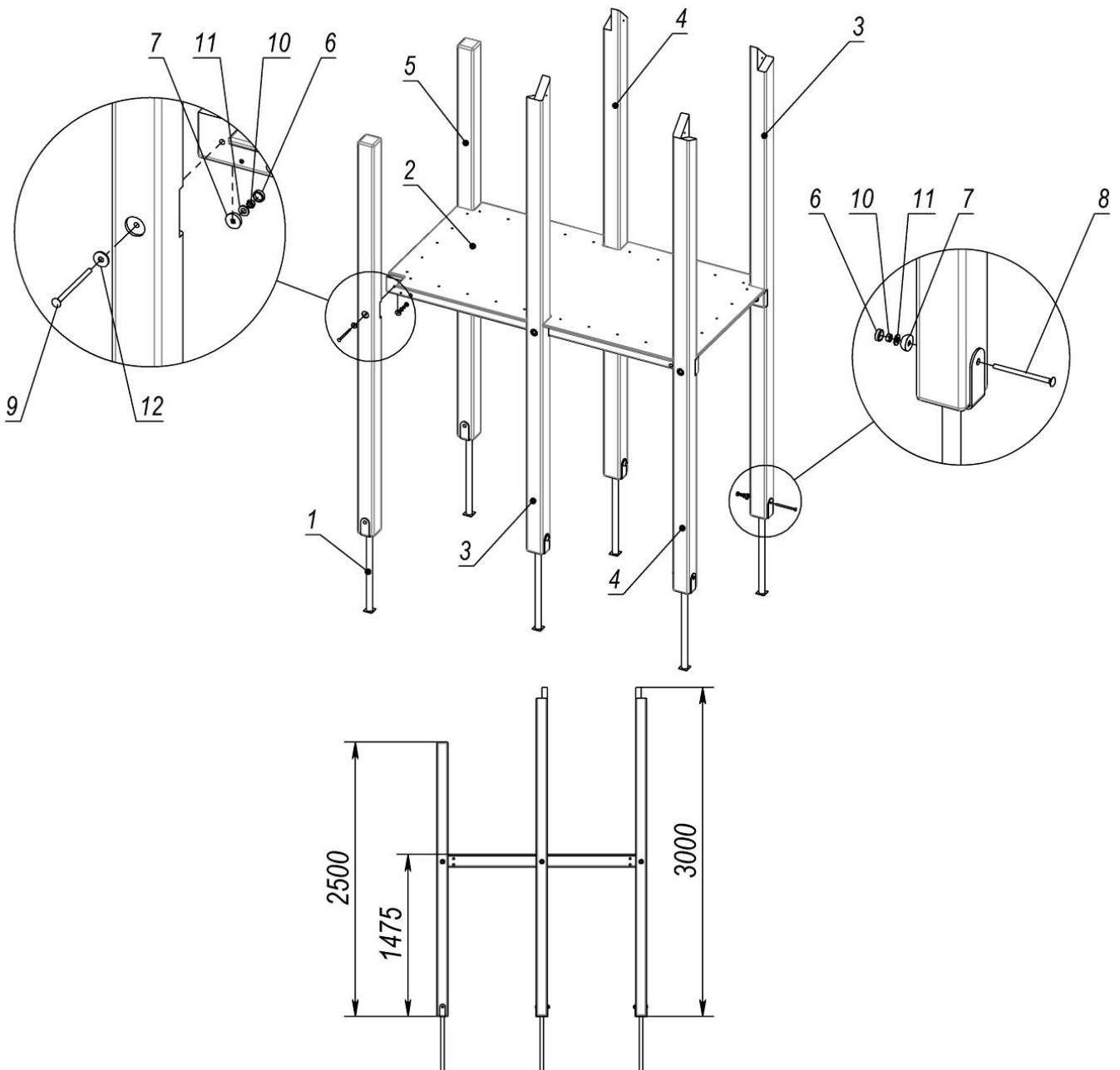

Pos.	Name	Weight, kg	Q-ty
1	Beam support	2	6
2	Double site (1.9x1m)	35	1
3	Beam 3m (mortise 1.5m)	17	2
4	Beam 3m (mortise 1.5m)	17	2
5	Beam 2.5m (mortise 1.5m)	15	2
6	Cap M8		12
7	Cup M8		12
8	Bolt M8*120 GOST7802		6
9	Bolt M8*130 GOST7802		6
10	Nut M8 GOST5915		12
11	Washer 10 GOST11371		12
12	Washer 10 GOST6958		8

**Picture 11 – Double tower 1,5m**

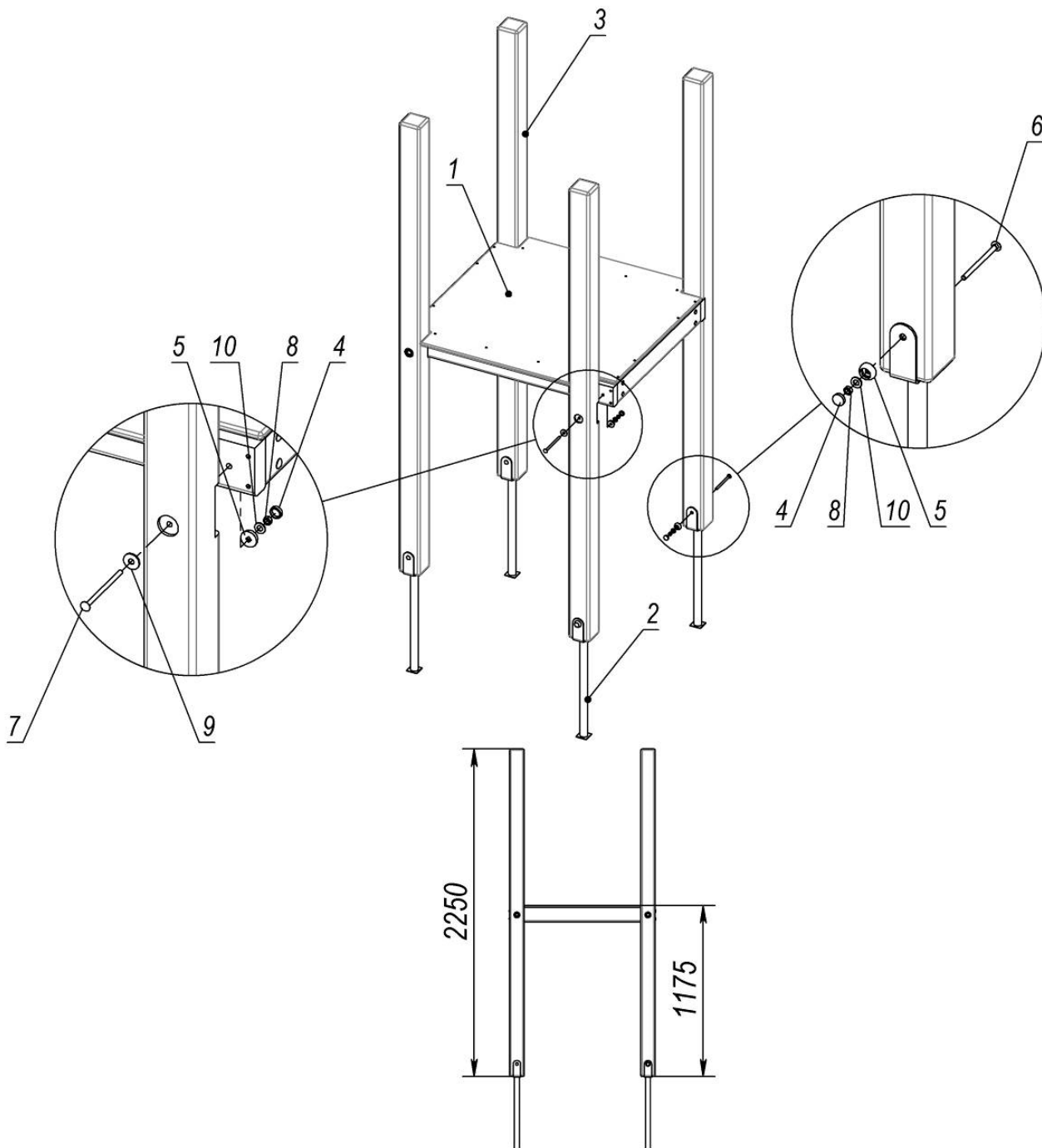

<i>Pos.</i>	<i>Name</i>	<i>Weight, kg</i>	<i>Q-ty</i>
1	Site 1x1 (standard)	19	1
2	Beam support	2	4
3	Beam 2.25 m	13	4
4	Cap M8		8
5	Cup M8		8
6	Bolt M8*120 GOST7802		4
7	Bolt M8*130 GOST7802		4
8	Nut M8 GOST5915		8
9	Washer 10 GOST6958		4
10	Washer 10 GOST11371		8

**Picture 12 – Tower 1,2m 1x1**

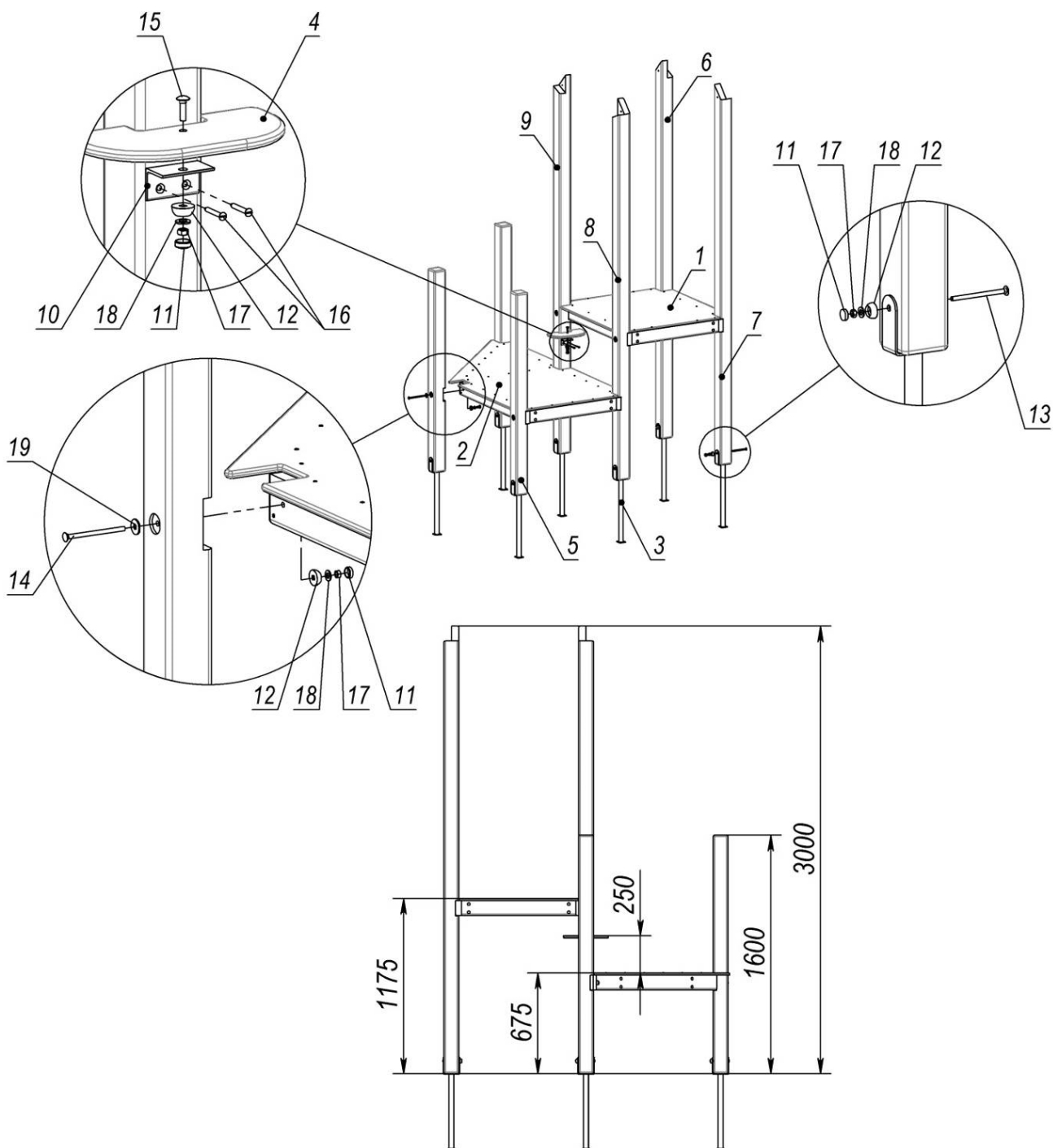

Pos.	Name	Weight, kg	Q-ty	Pos.	Name	Weight, kg	Q-ty
1	Site 1x1m	19	1	11	Cap M8		17
2	Double site (1x1.9) angled	31	1	12	Cup M8		17
3	Beam support	2	7	13	Bolt M8*120 GOST7802		7
4	Step (150x300)		1	14	Bolt M8*130 GOST7802		9
5	Beam 1.6m (mortise 0.7m)	9	3	15	Bolt M8*30 GOST7802		1
6	Beam 3m (mortise 1.2)	17	1	16	Screw 6x50 GOST1145		2
7	Beam 3m (mortise 1.2)	17	1	17	Nut M8 GOST5915		17
8	Beam 3m (mortise 1.2-0.7)	17	1	18	Washer 10 GOST11371		17
9	Beam 3m (mortise 1.2-0.7)	17	1	19	Washer 10 GOST6958		10
10	Big angle bar		1				

**Picture 13 – Triple tower 0,7-0,7-1,2m**

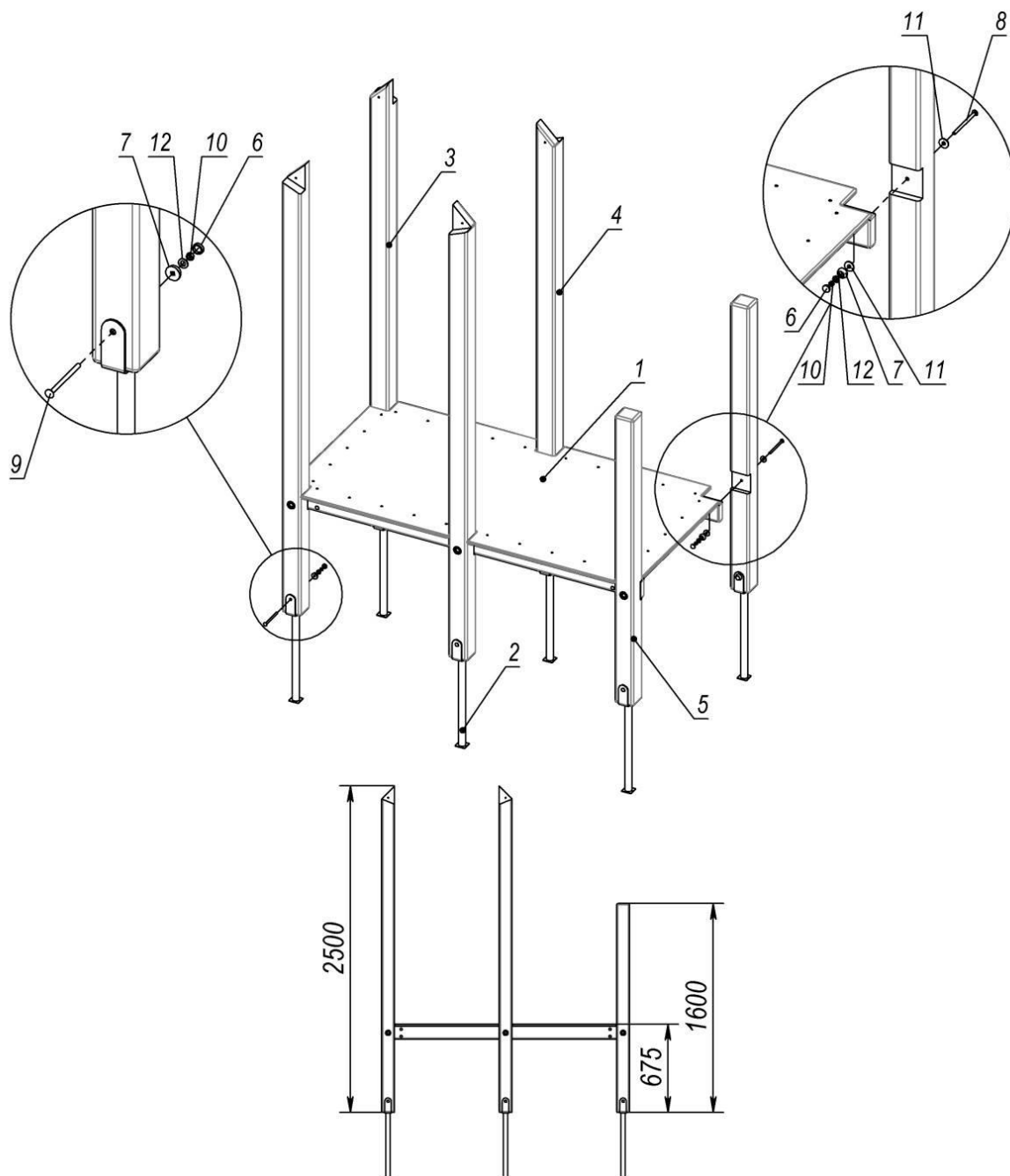

Pos.	Name	Weight, kg	Q-ty
1	Double site (1.9x1m)	35	1
2	Beam support	2	6
3	Beam 2.5m (mortise 0.7)	14	2
4	Beam 2.5m (mortise 0.7)	14	2
5	Beam 1.6m (mortise 0.7)	9	2
6	Cap M8		12
7	Cup M8		12
8	Bolt M8*130 GOST7802		6
9	Bolt M8*120 GOST7802		6
10	Nut M8 GOST5915		12
11	Washer 10 GOST6958		10
12	Washer 10 GOST11371		12

Picture 14 – Double tower 0,7m

Assembly scheme of roof for multi-level tower

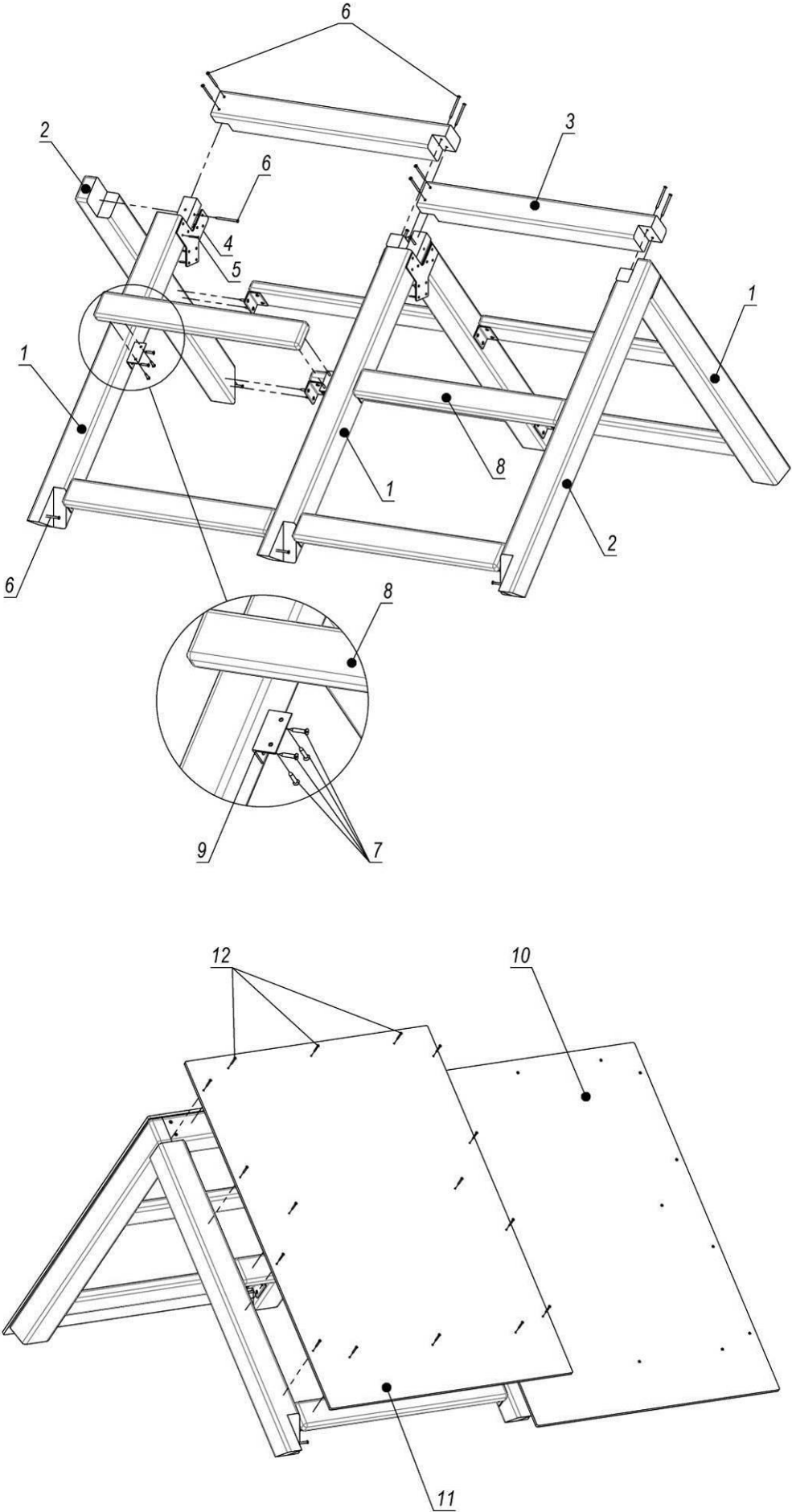

Picture 15

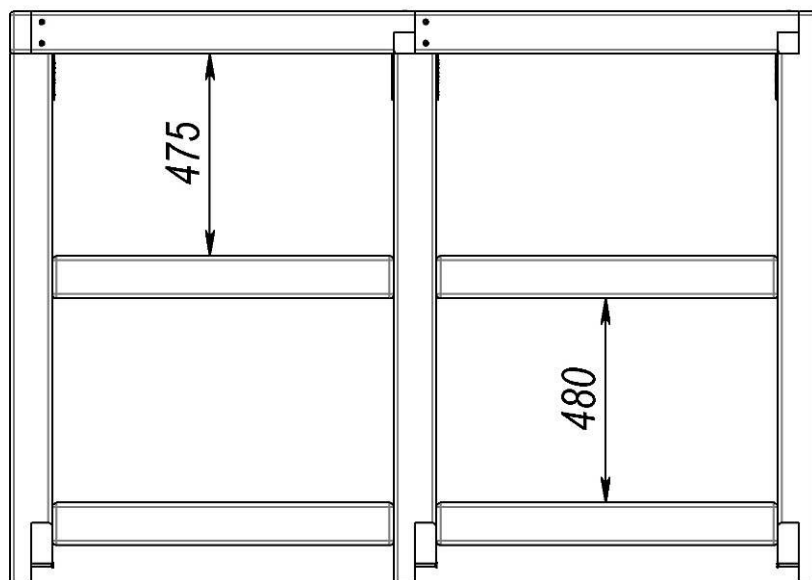

<i>Pos.</i>	<i>Name</i>	<i>Weight, kg</i>	<i>Q-ty</i>
1	<i>Rear pediment</i>	7	4
2	<i>Front pediment</i>	7	2
3	<i>Ridge (100x100x900)</i>	5	2
4	<i>Two-sided angle bar</i>		4
5	<i>Screw 4x40 GOST1145</i>		40
6	<i>Screw 6x90 GOST1145</i>		18
7	<i>Screw 6x35 GOST1145</i>		64
8	<i>Support</i>	2	8
9	<i>Angle bar 80 mm</i>		16
10	<i>Roof slope (950x1400)</i>	14	2
11	<i>Roof slope (950x1400)</i>	14	2
12	<i>Screw 4x40 GOST1144</i>		64

**Picture 15.1 – Assembly scheme of roof 2x2m**

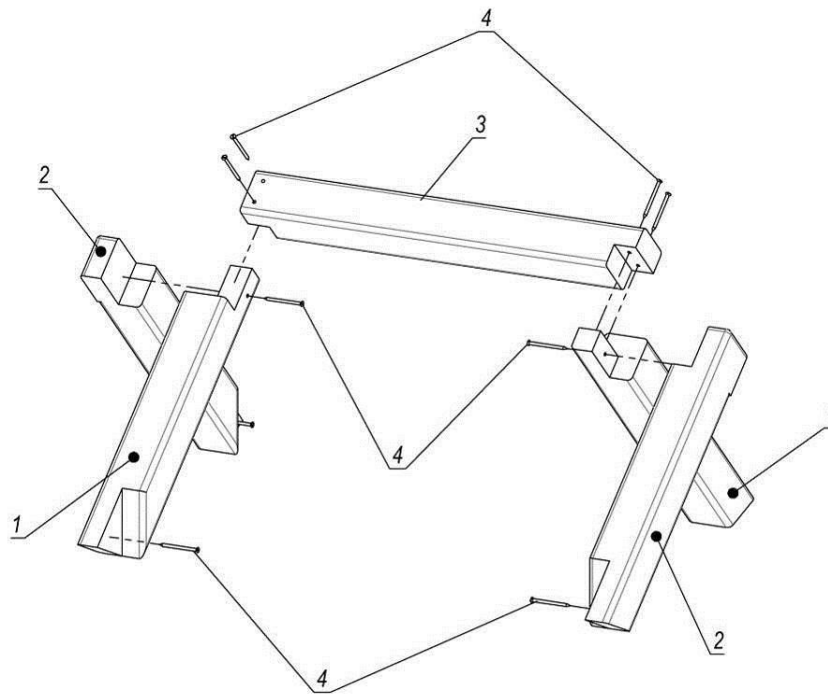

Pos.	Name	Weight, kg	Q-ty
1	Rear pediment		2
2	Front pediment		2
3	Ridge (100x100x900)	5	1
4	Screw 6x90 GOST1145		10

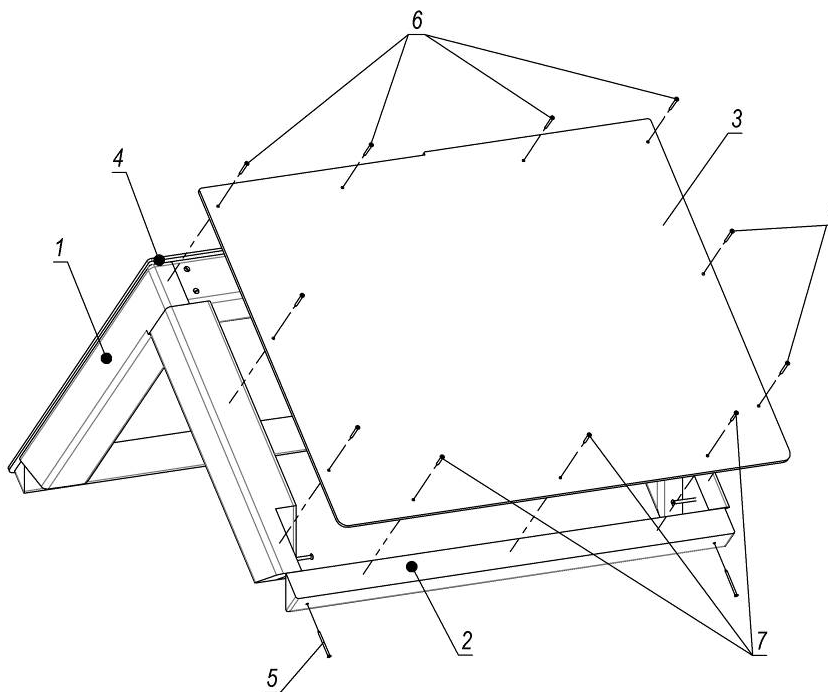

Pos.	Name	Weight, kg	Q-ty
1	Roof	19	1
2	Bar 970 mm		2
3	Roof slope (775x1000)	5	1
4	Roof slope (775x1000)	5	1
5	Screw 4x60 GOST1145		4
6	Screw 4x40 GOST1145		16
7	Screw 4x30 GOST1145		6

**Picture 16 – Roof assembly scheme**

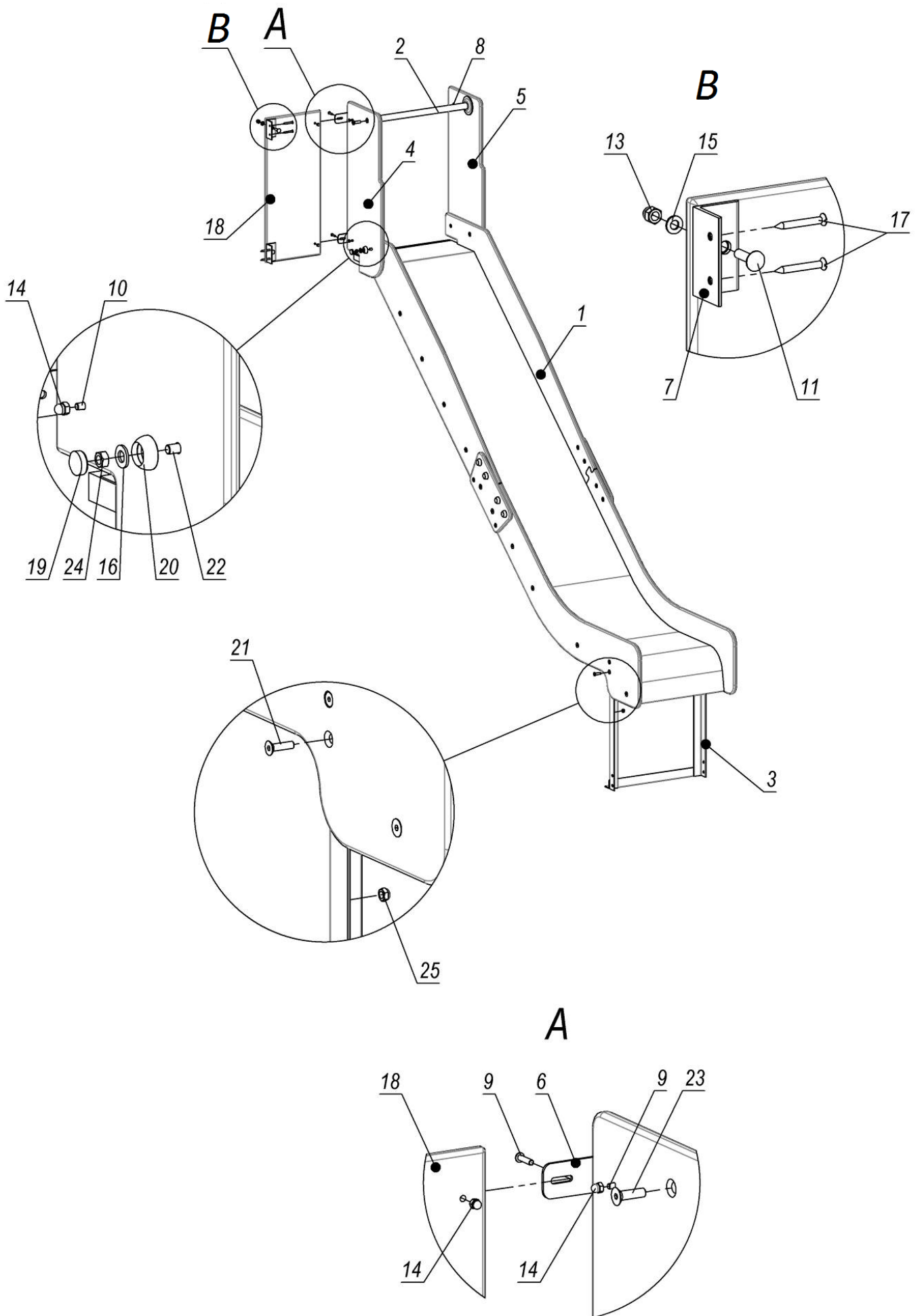

Picture 17

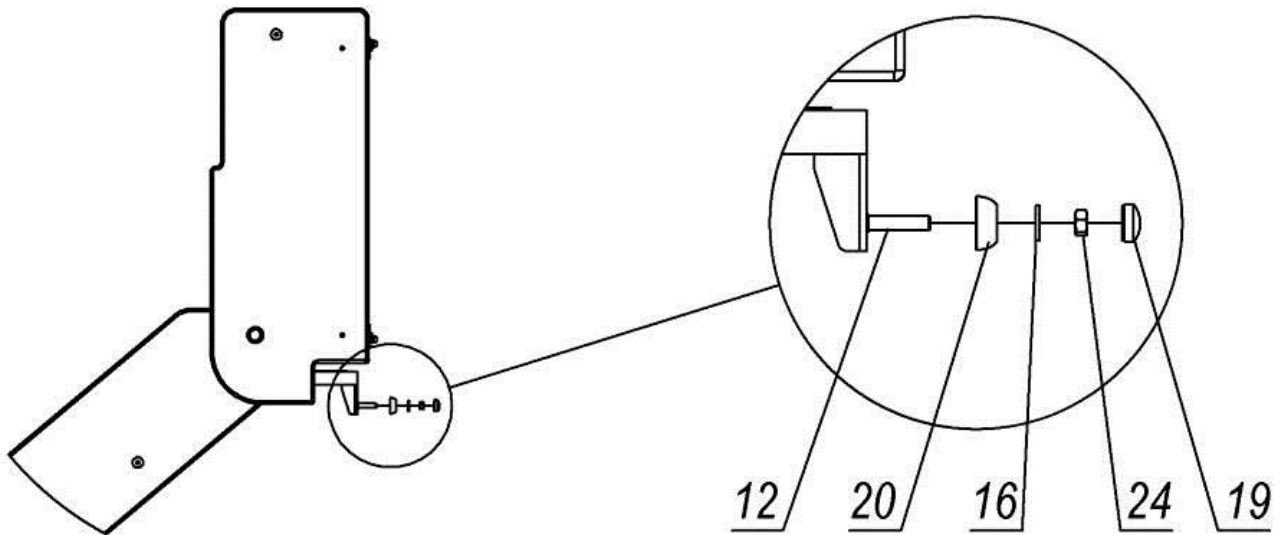

Pos.	Name	Weight, kg	Q-ty
1	Slide 1.5m	44	1
2	Brace rod 493 mm	1	1
3	Slide Embedded element (angle bar)	5	1
4	Upper right sidewall	3	1
5	Upper left sidewall	3	1
6	Slide angle bar		2
7	Big angle bar		2
8	Screw 6.0x60 SPAX T-STAR plus with press washer (univers.)		2
9	Stud M6x25 ISO7380		3
10	Stud M6x40 ISO7380		1
11	Bolt M8*30 GOST7802		2
12	Bolt M8*40 GOST7802		2
13	Cap nut M8 DIN1587		2
14	Cap nut M6 DIN1587		4
15	Washer 8 GOST11371		2
16	Washer 10 GOST11371		4
17	Screw 6x50 GOST1145		4
18	Partition (275x650)	3	1
19	Cap M8		4
20	Cup M8		4
21	Stud M8x30 DIN7991		4
22	Stud M8x40 DIN7991		2
23	Stud M10x35 DIN7991		2
24	Nut M8 GOST5915		4
25	Nut M8 DIN985		4

Picture 17.1 – Assembly scheme of slide 1,5m

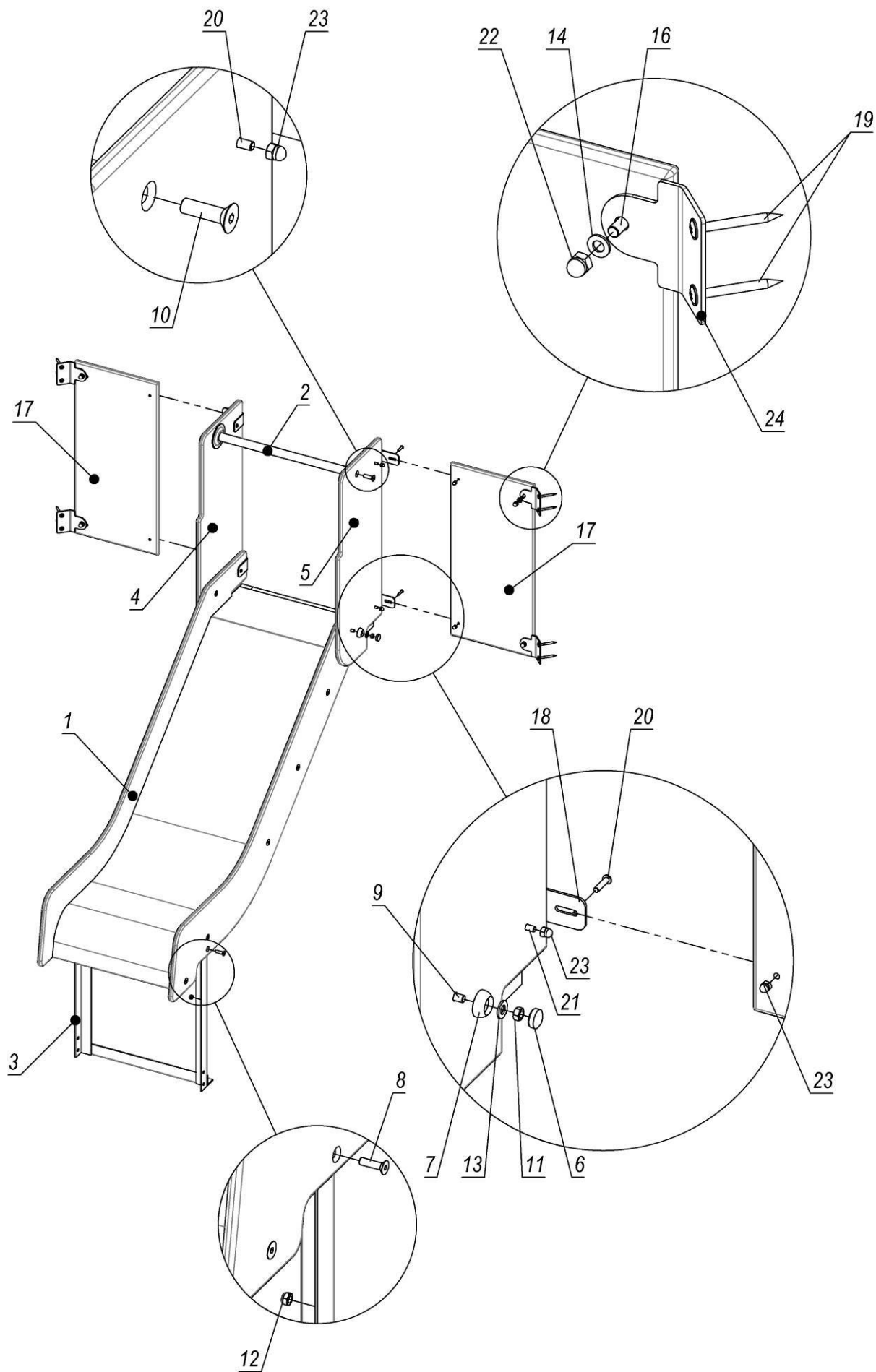

Picture 18

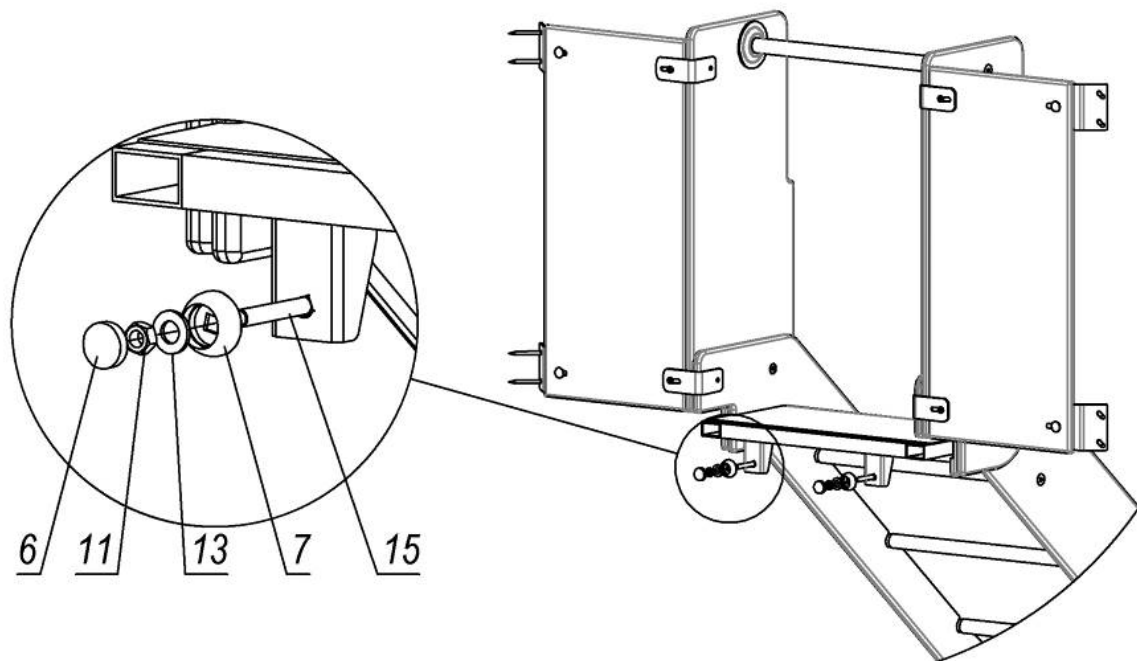

Pos.	Name	Weight, kg	Q-ty
1	Slide 0.7m	21	1
2	Brace rod 493 mm	1	1
3	Slide embedded element (angle bar)	5	1
4	Upper right sidewall	3	1
5	Upper left sidewall	3	1
6	Cap M8		4
7	Cup M8		4
8	Stud M8x30 DIN7991	14	4
9	Stud M8x40 DIN7991	18	2
10	Stud M10x35 DIN7991	26	2
11	Nut M8 GOST5915		4
12	Nut M8 DIN985		4
13	Washer 10 GOST11371		4
14	Washer 8 GOST11371		4
15	Bolt M8*55 GOST7802		2
16	Bolt M8*30 GOST7802		4
17	Partition (306-650)	3	2
18	Slide angle bar		4
19	Screw 6.0x60 SPAX T-STAR plus with press washer (univers.)		8
20	Stud M6x25 ISO7380		6
21	Stud M6x40 ISO7380		2
22	Cap nut M8 DIN1587		4
23	Cap nut M6 DIN1587		8
24	Angle bar 135 degrees		4

**Picture 18.1 – Assembly scheme of slide 0,7m with two partitions**

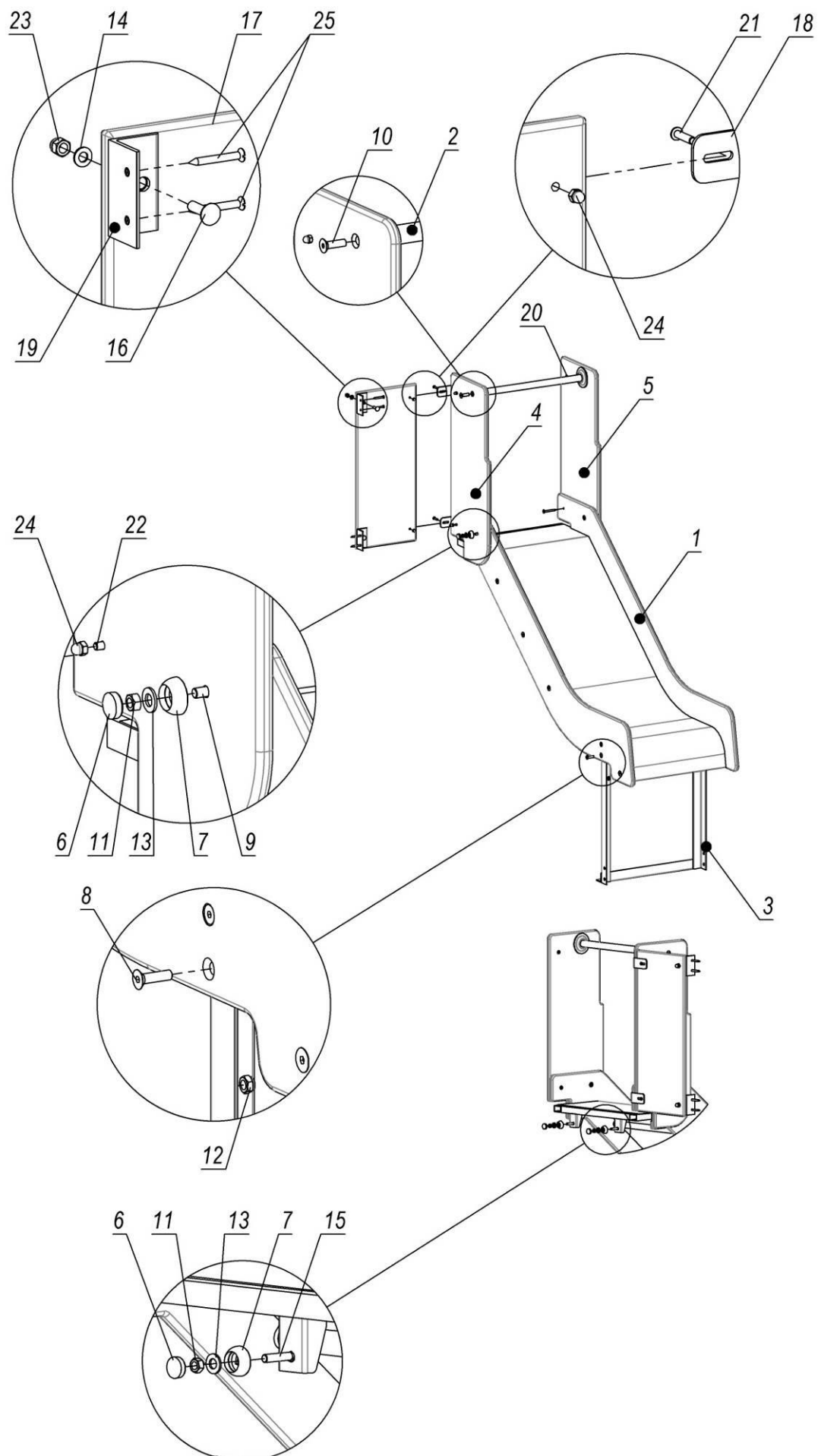

Picture 19 – Assembly scheme of slide 0,7m with one partition

**Table №1 – Completeness of slide 0,7m**

<i>Pos.</i>	<i>Name</i>	<i>Weight, kg</i>	<i>Q-ty</i>
1	<i>Slide 0.7m</i>	21	1
2	<i>Brace rod 493mm</i>	1	1
3	<i>Slide embedded element</i>	5	1
4	<i>Upper right sidewall</i>	3	1
5	<i>Upper left sidewall</i>	3	1
6	<i>Cap M8</i>		4
7	<i>Cup M8</i>		4
8	<i>Stud M8x30 DIN7991</i>	14	4
9	<i>Stud M8x40 DIN7991</i>	18	2
10	<i>Stud M10x35 DIN7991</i>	26	2
11	<i>Nut M8 GOST5915</i>		4
12	<i>Nut M8 DIN985</i>		4
13	<i>Washer 10 GOST11371</i>		4
14	<i>Washer 8 GOST11371</i>		2
15	<i>Bolt M8*40 GOST7802</i>		2
16	<i>Bolt M8*30 GOST7802</i>		2
17	<i>Partition (275x650)</i>	3	1
18	<i>Slide angle bar</i>		2
19	<i>Big angle bar</i>		2
20	<i>Screw 6.0x60 SPAX T-STAR plus (univers.)</i>		2
21	<i>Stud M6x25 ISO7380</i>		3
22	<i>Stud M6x40 ISO7380</i>		1
23	<i>Cap nut M8 DIN1587</i>		2
24	<i>Cap nut M6 DIN1587</i>		4
25	<i>Screw 6x50 GOST1145</i>		4

**Assembly scheme of spiral slide**  
(Assemble the tubes of the slide from top to bottom)

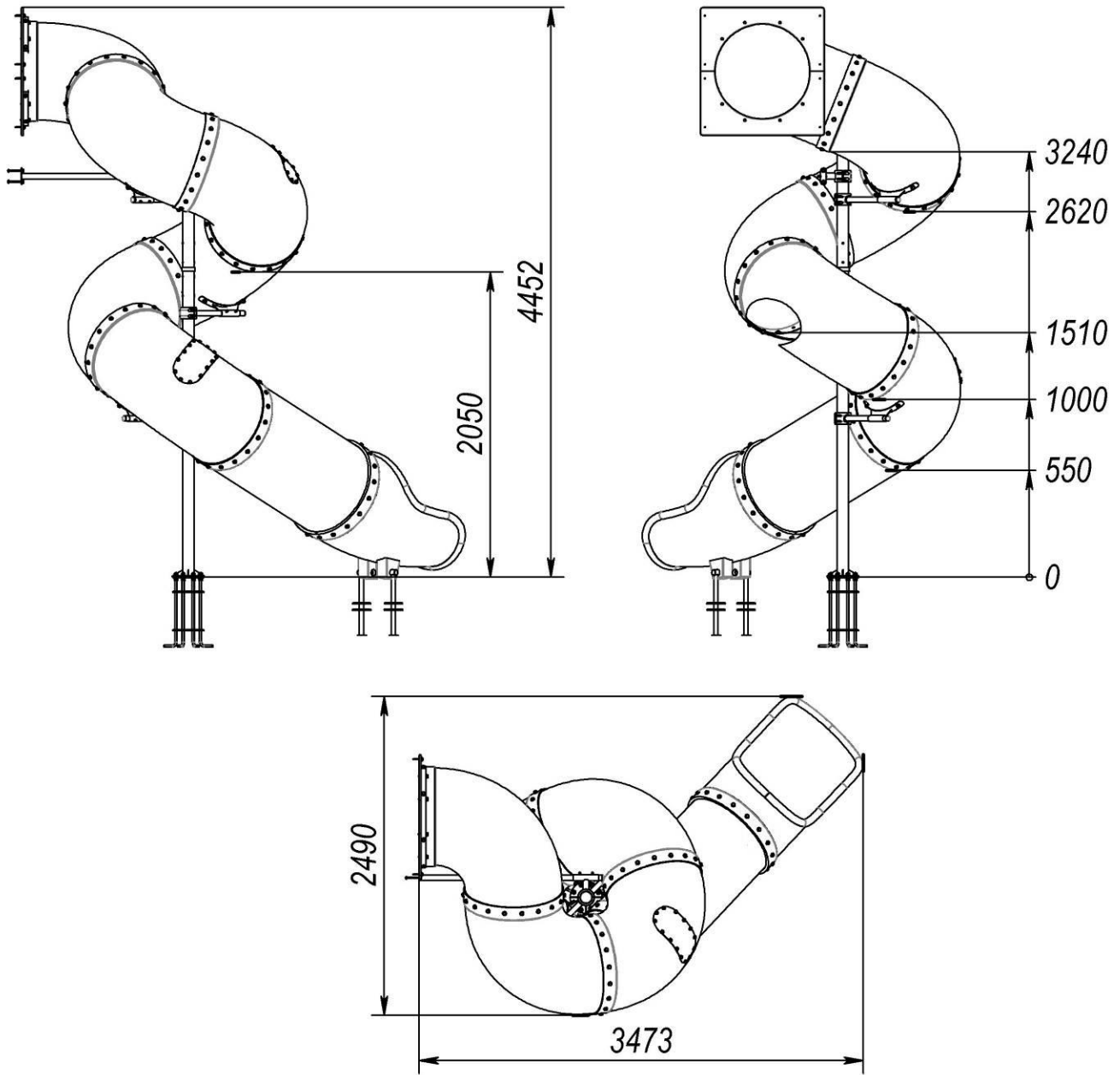

**Picture 20 – Overall dimensions**

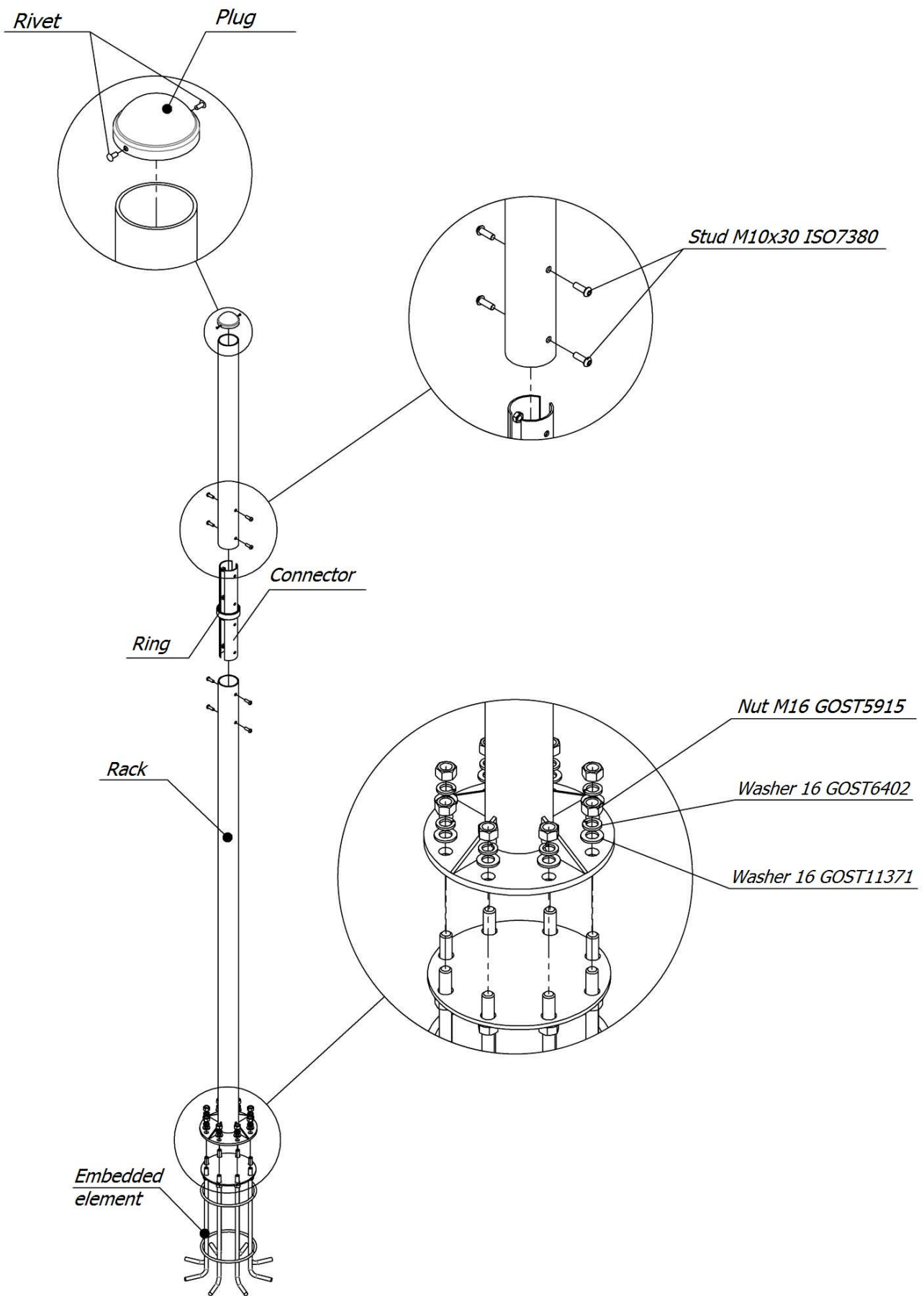

**Picture 21 – Assembly scheme of Rack**

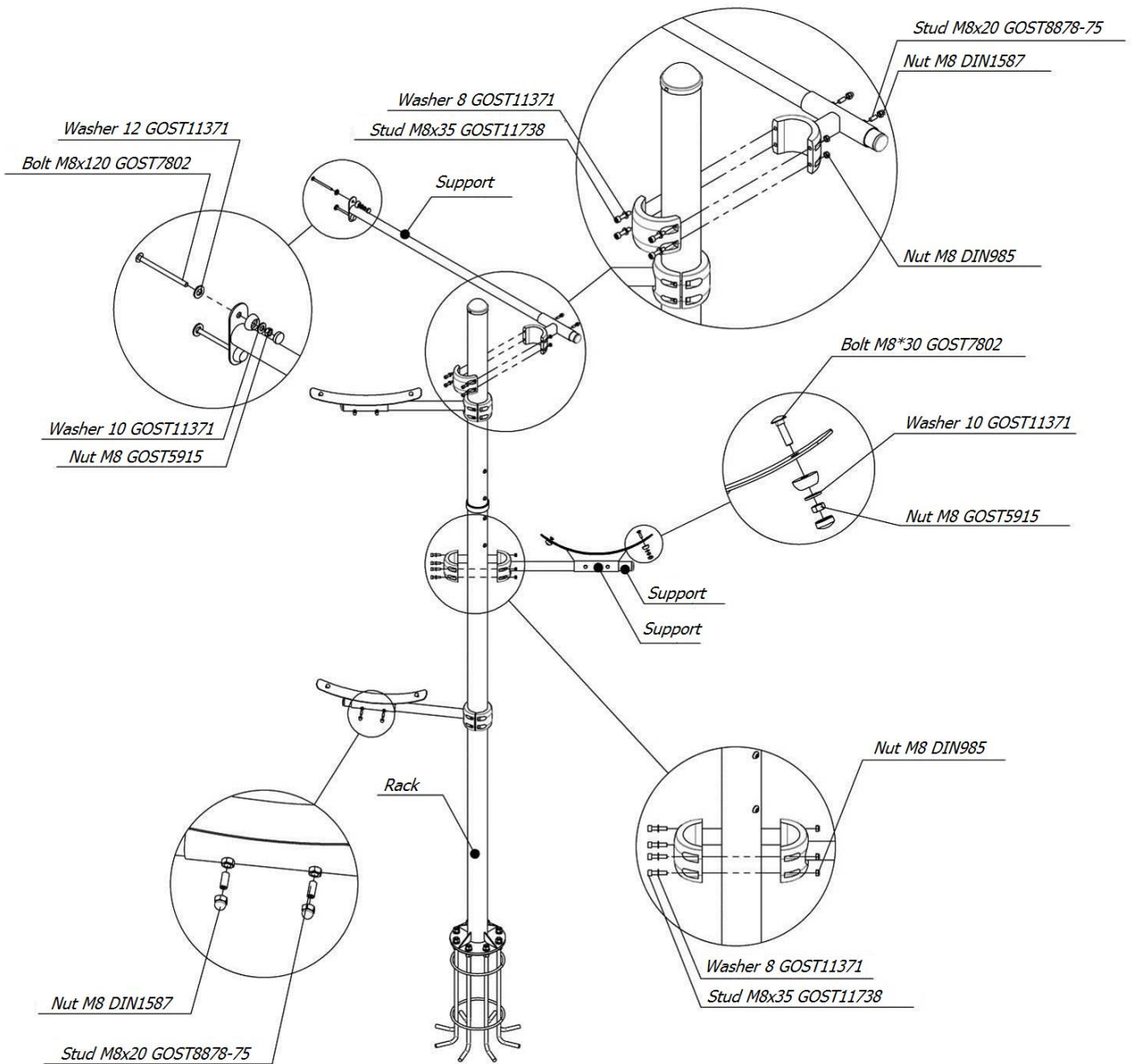

**Picture 22 – Fastening scheme of supports**

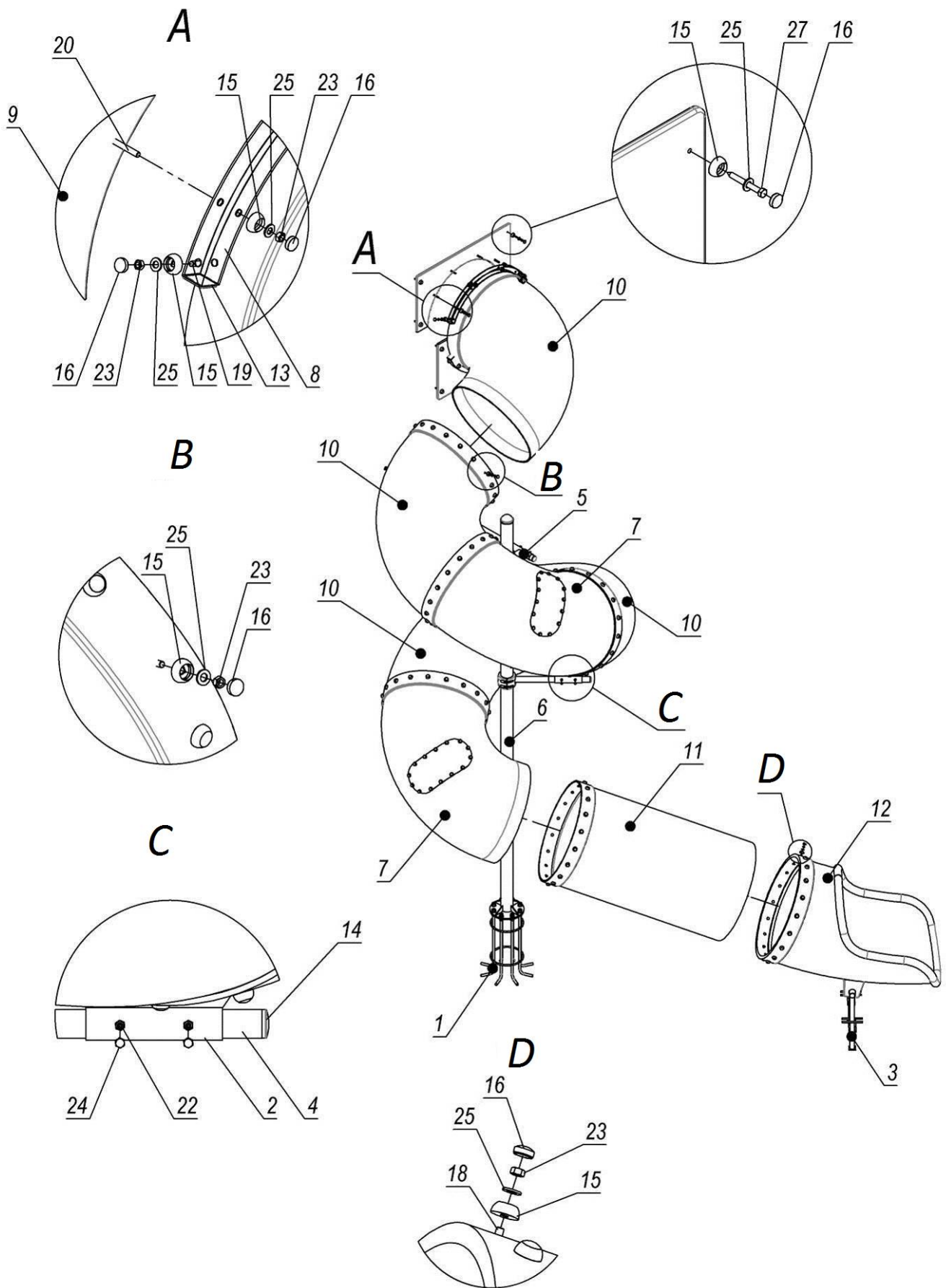

Picture 23 – Connecting scheme of tubes

**Table 2 – Completeness of spiral slide**

<i>Pos.</i>	<i>Name</i>	<i>Weight, kg</i>	<i>Q-ty</i>
1	<i>Foundation (8 anchors assembly)</i>	12	1
2	<i>Support</i>	1	3
3	<i>Embedded element (slide-tube)</i>	2	2
4	<i>Support assembly</i>	6	3
5	<i>Support assembly</i>	9	1
6	<i>Rack 4.0m</i>	36	1
7	<i>Section with window assembly</i>	23	2
8	<i>Tunnel half-clamp</i>	2	2
9	<i>Entrance</i>	4	2
10	<i>Tube turning 760</i>		4
11	<i>Straight tube 760</i>	30	1
12	<i>Tube whistle 760</i>	49	1
13	<i>Plug 40x40</i>		4
14	<i>Plug DN32R</i>		4
15	<i>Cup M8</i>		158
16	<i>Cap M8</i>		158
17	<i>Bolt M8*30 GOST7802</i>		114
18	<i>Bolt M8*45 GOST7802</i>		18
19	<i>Bolt M8*60 GOST7802</i>		12
20	<i>Bolt M8*65 GOST7802</i>		8
21	<i>Bolt M8*120 GOST7802</i>		2
22	<i>Stud 8x20 GOST8878-93</i>		6
23	<i>Nut M8 GOST5915</i>		150
24	<i>Cap nut M8 DIN1587</i>		6
25	<i>Washer 10 GOST11371</i>		158
26	<i>Washer 12 GOST11371</i>		2
27	<i>Screw 8x70 GOST11473</i>		8

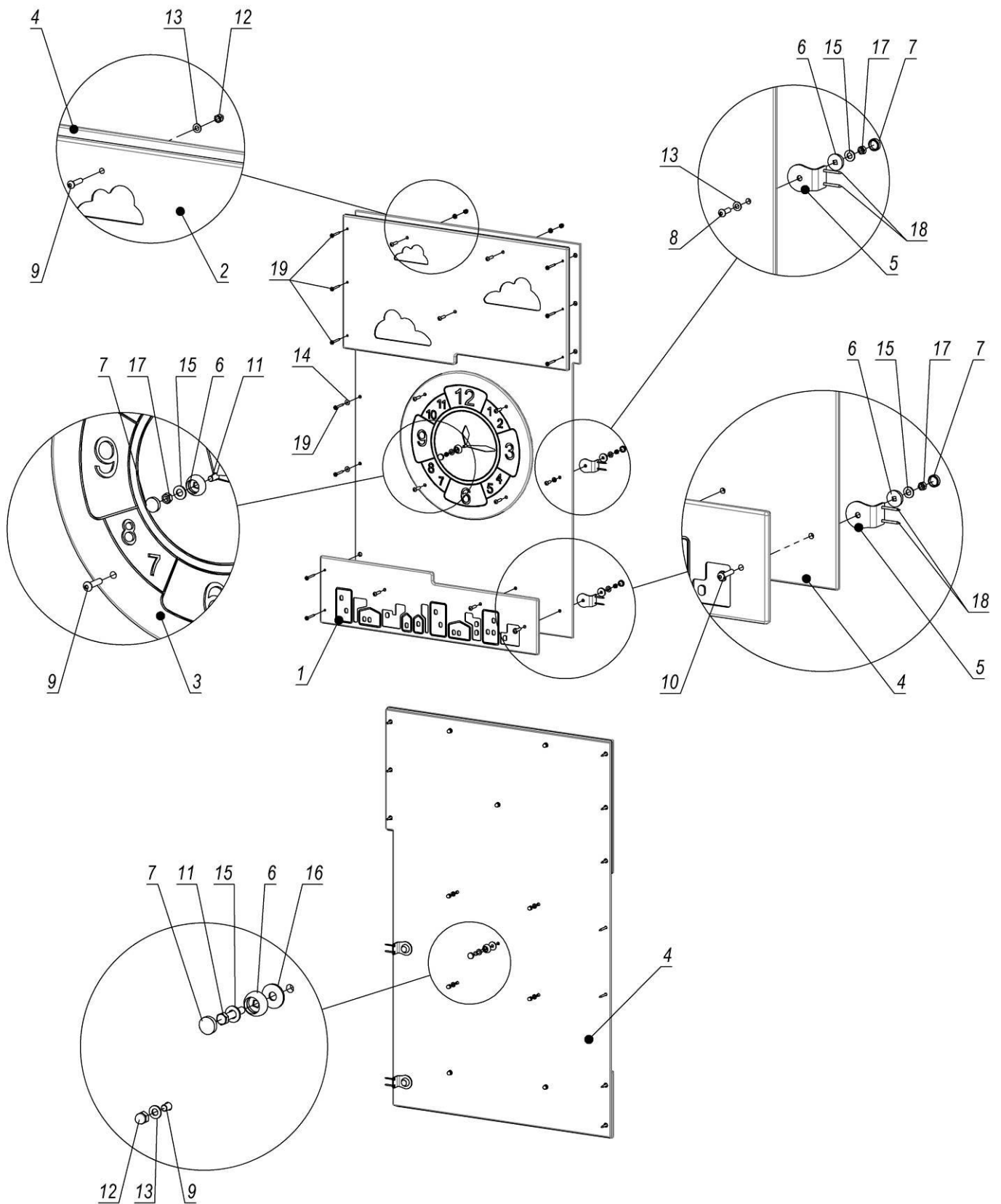

**Picture 24 – Assembly scheme of panel with clock**

**Table №3 – Completeness of panel with clock**

<i>Pos.</i>	<i>Name</i>	<i>Weight, kg</i>	<i>Q-ty</i>
1	Lower panel	3	1
2	Upper panel with clouds	6	1
3	Cover plate "Clock"	3	1
4	Transparent panel (0.94x1.48)	15	1
5	Corner bracket 40x60		2
6	Cup M8		4
7	Cap M8		4
8	Stud M8x25 ISO7380		1
9	Stud M8x35 ISO7380		9
10	Stud M8x40 ISO7380		1
11	Bolt M8*45 GOST 7798		1
12	Cap nut M8 DIN1587		9
13	Washer 8 GOST11371		10
14	Washer 6 GOST6958		2
15	Washer 10 GOST11371		4
16	Washer 10 GOST6958		1
17	Nut M8 GOST5915		3
18	Screw 4x40 GOST1145		4
19	Screw 6.0x60 SPAX T-STAR plus with press washer (univers.)		11

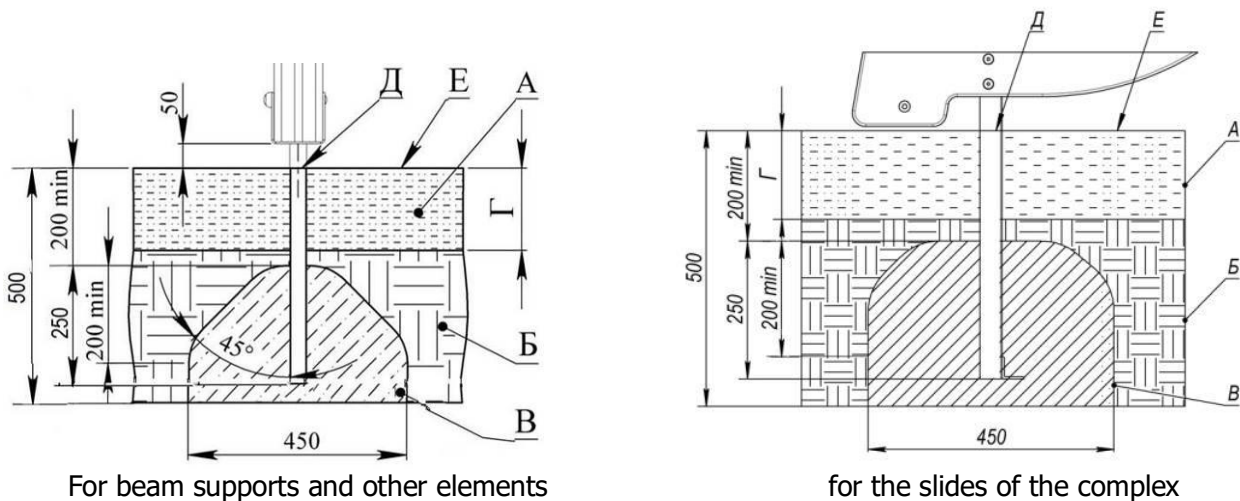

For beam supports and other elements

for the slides of the complex

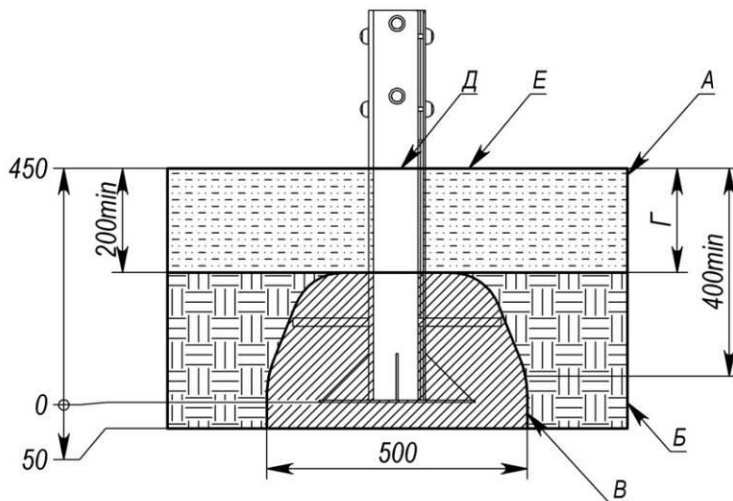

For multi-level tower beams

*A - shock-absorbing coating;*

*B – soil;*

*B – concrete;*

*Г - depth of the shock absorbing coating;*

*Д - product level plane;*

*E – game surface.*

**Examples of impact-absorbing coatings**

Material <sup>1</sup>	Description	Minimal depth, mm	Height of fall, mm
Turf			≤1000
Tree bark	grain size 20-80 mm	200	≤2000
		300	≤3000
Sawdust	grain size 5-30 mm	200	≤2000
		300	≤3000
Sand <sup>2</sup>	grain size 0,2-2 mm	200	≤2000
		300	≤3000
Gravel <sup>2</sup>	grain size 2-8 mm	200	≤2000
		300	≤3000
Another material	HIC tested according to EN1177	According to the test	According to the test

1. Materials specially prepared for playgrounds.  
 2. There should not be any clay inclusions. The grain size is obtained by sieving through a sieve as in EN933-1.

**Picture 25 – Concreting scheme**



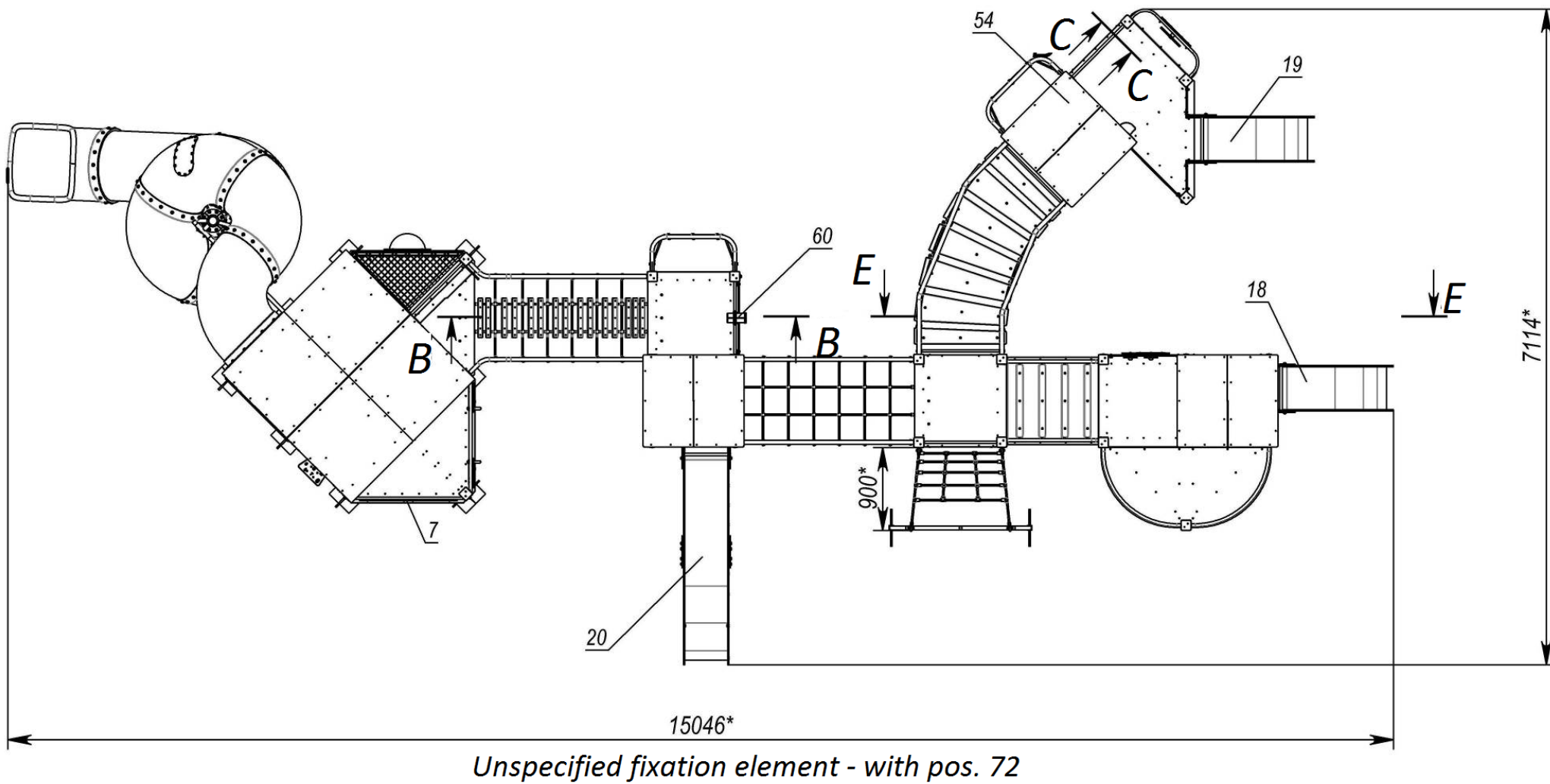

Picture 27

Pos.	Name	Weight, kg	Q-ty	Pos.	Name	Weight, kg	Q-ty
1	Binoculars		1	46	Lower panel	3	1
2	Corner bracket		2	47	Panel fencing (1.3*0.3m)	5	1
3	Rope embedded element		2	48	Fastening flange 580 mm	2	4
4	Handle		7	49	Panel "Climbing frame"	7	1
5	Radius site	34	1	50	Panel "Showcase" 0.75m	7	1
6	Mesh corner bracket	9	2	51	Panel Misto lower	3	1
7	Vertical rope mesh	20	2	52	Panel with clouds upper	6	1
8	Fencing-mesh corner	10	1	53	Bar 970 mm		6
9	Beam assembly	11	1	54	Roof slope (775x1000)	5	3
10	Double tower 1.5m	143	1	55	Roof slope (775x1000)	5	3
11	Tower 1.2m 1x1	79	1	56	Panel for drawing (1x1.25)	13	1
12	Triple tower 0.7-0.7-1.2m	159	1	57	Shield fencing		6
13	Tower 0.7m double	121	1	58	Table with numbers		1
14	Multi-level tower (2.8*2.8*6m)	985	1	59	Balcony (0.9m) with steering wheel		1
15	Wooden corner right fencing	24	2	60	Tube d12x1.5 GOST10704, L=22mm		8
16	Wooden corner left fencing		1	61	Cap M8		136
17	Roof	19	3	62	Cup M8		136
18	Slide Ukrhimplast (3.5m)	319	1	63	Cup M6		2
19	Slide 0.7m assembly	37	1	64	Cap M6		2
20	Slide 0.7m assembly	37	1	65	Bolt M6*35 GOST7802		2
21	Slide 1.5m assembly	60	1	66	Bolt M8*30 GOST7802		12
22	Rope bridge 0.95x1.9	29	1	67	Bolt M8*45 GOST7802		9
23	Rope corner bridge 0.95x1.9	32	1	68	Bolt M8*60 GOST7802		16
24	Rope walkway 1.9 arched	71	1	69	Bolt M8*120 GOST7802		4
25	Inclined walkway	26	1	70	Stud M6x25 DIN7991		8
26	Brace rod 0.8m	1	4	71	Stud M8x25 ISO7380		1
27	Panel with windows		3	72	Stud M8x30 ISO7380		88
28	Panel "Gear wheels" (0.75m) assembly		1	73	Nut M6 GOST5915		2
29	Panel "World map" (0.75m) assembly		1	74	Nut M8 GOST5915		105
30	Panel "Sweets" (0.75m) assembly	10	1	75	Cap nut M6 DIN1587		8
31	Showcase angle bar		2	76	Cap nut M8 DIN1587		23
32	Handrail	14	2	77	Nut M8 DIN985		22
33	Rope ladder 1.2m	5	1	78	Washer 10 GOST11371		136
34	Stairs 0.7m	12	1	79	Washer 12 GOST6958		4
35	Bracket for thimble		4	80	Washer 8 GOST11371		22
36	Corner bracket 40x60		86	81	Screw 6.0x60 SPAX T-STAR plus (univers.)		253
37	Cap on bar		11	82	Screw 4x40 GOST1145		194
38	Coverings over slide	7	1	83	Washer 10 GOST6958		1
39	Lower cover plate (0.25m)	3	1	84	Stud M8x35 ISO7380		19
40	Upper cover plate with clouds	7	1	85	Washer 6 GOST6958		10
41	Panel (0.94x1.35)	14	1	86	Stud M8x40 ISO7380		1
42	Cover plate "Clock"	3	1	87	Screw 4x60 GOST1145		12
43	Transparent panel (0.94x1.48)	15	1	88	Screw 4x40 GOST1144		48
44	Upper panel birds	3	1	89	Screw 4x30 GOST1144		18
45	Panel (0.94x1.35)	14	1				

Picture 28

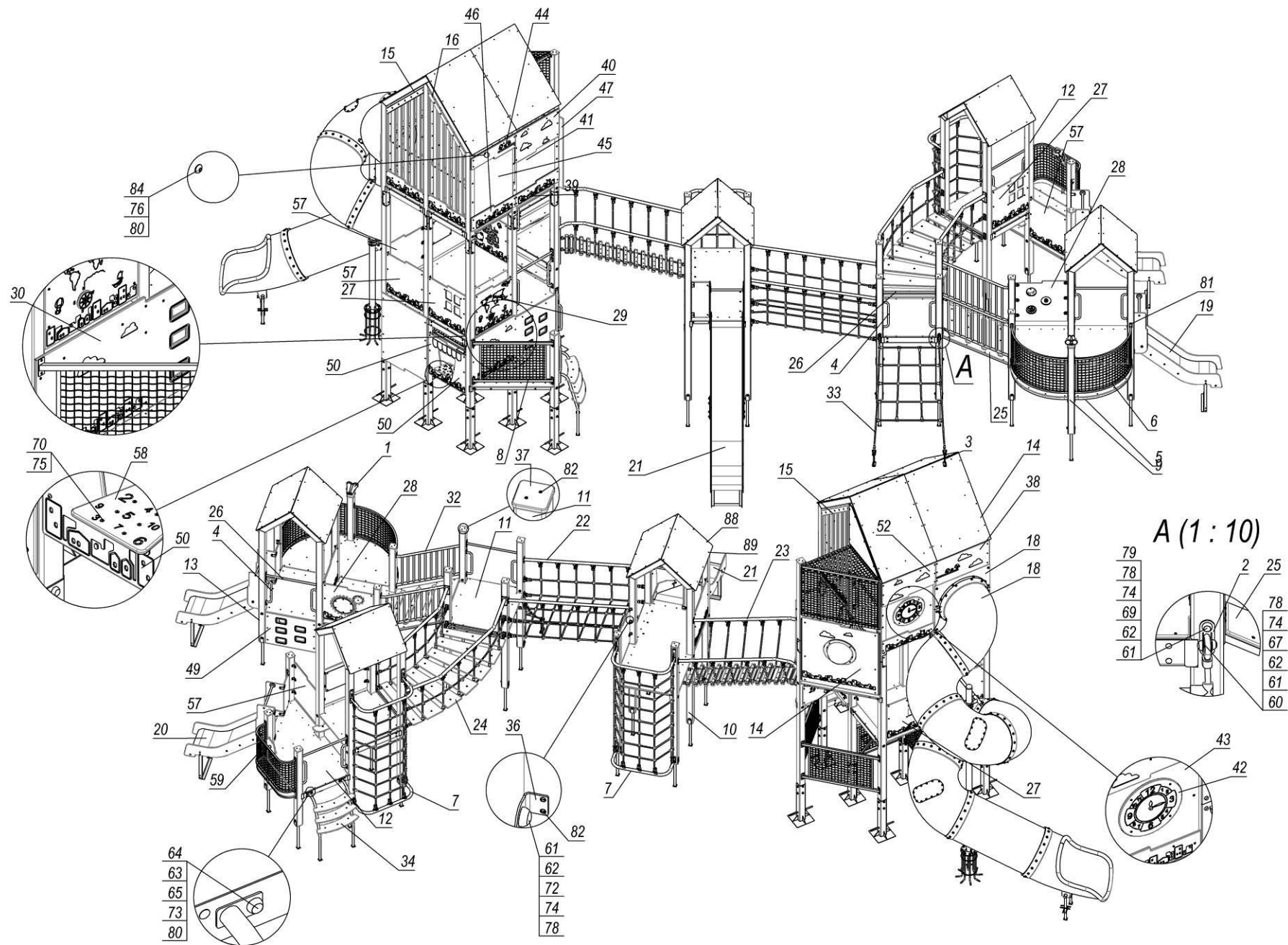

Picture 29

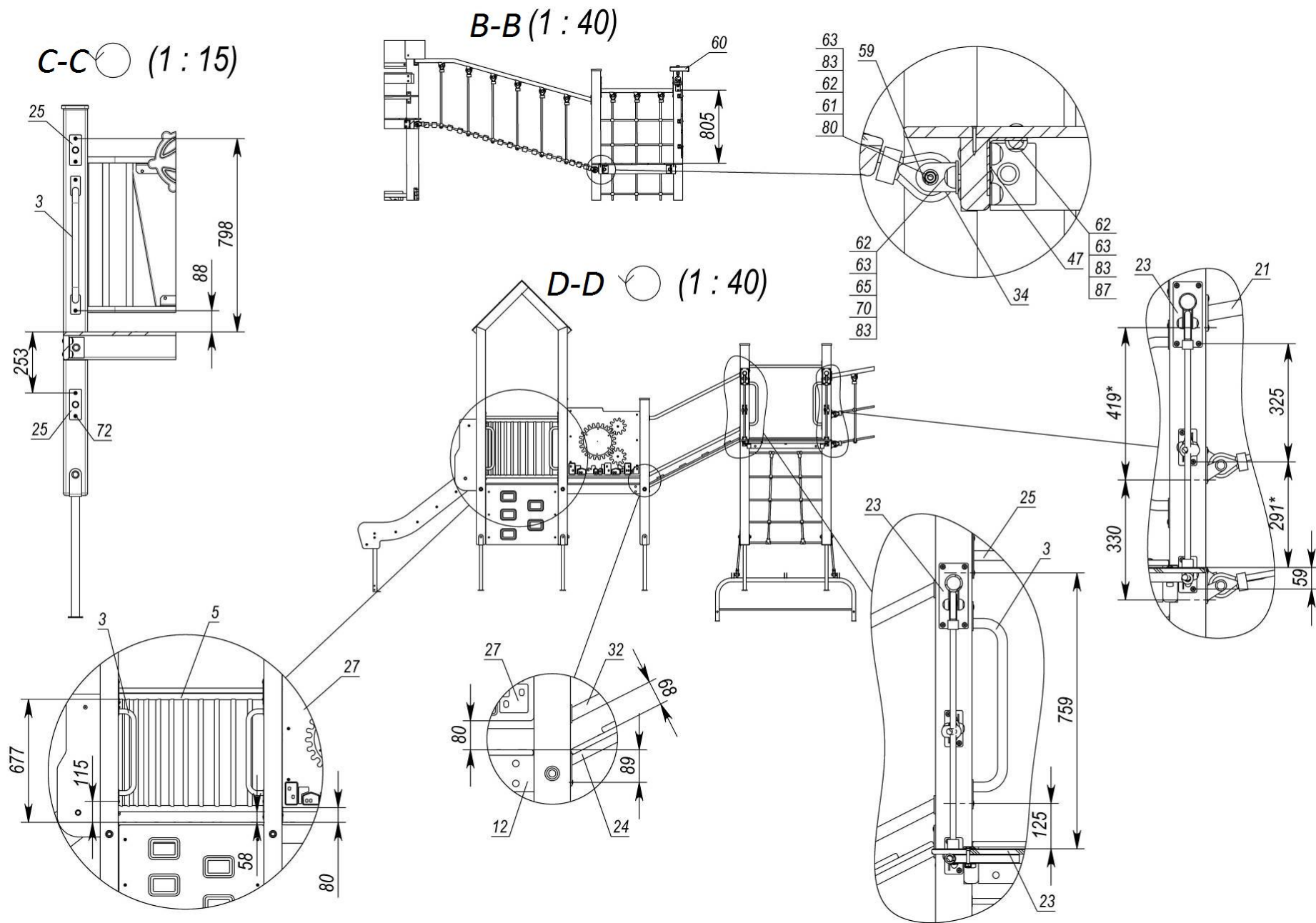

Picture 30

# Module of multi-level tower

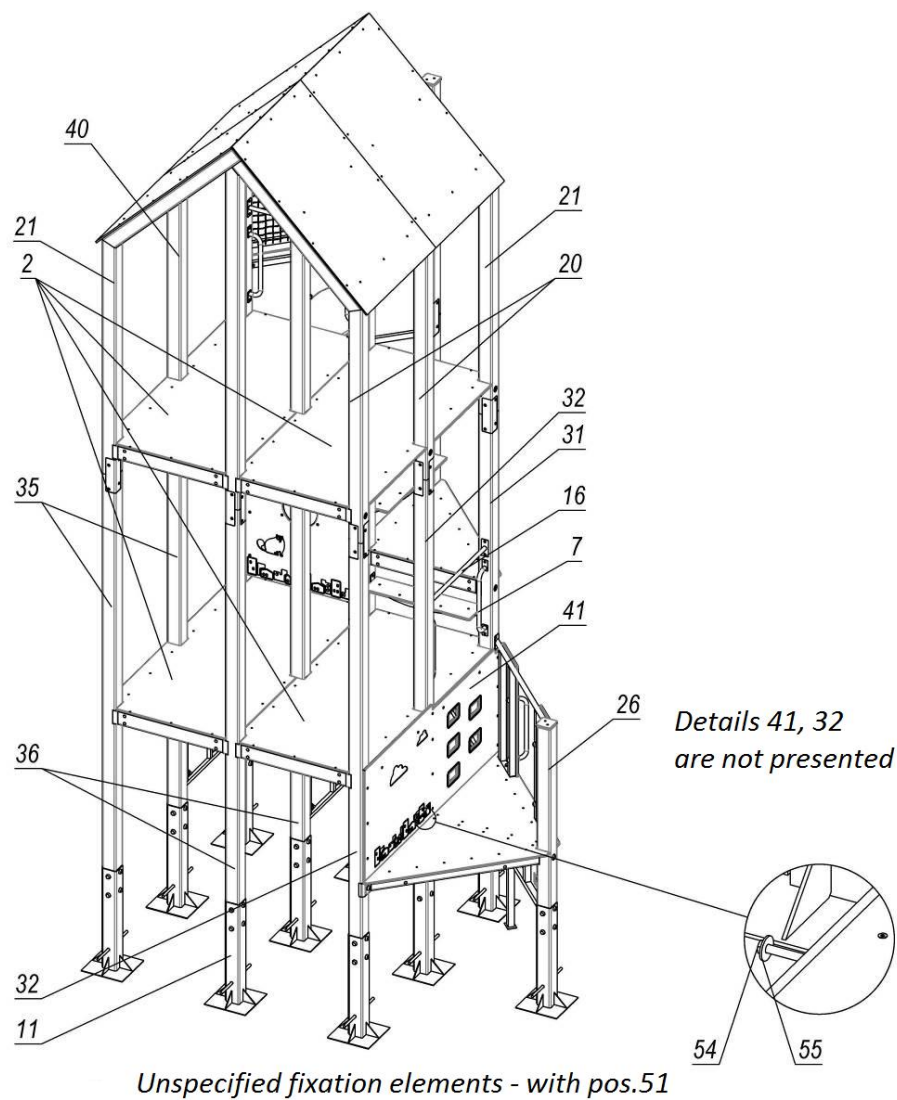

**Picture 31**

Pos.	Name	Weight	Q-ty
1	3-edged playground	14	2
2	Double playground	34	4
3	Double playground (1x1,9) angle	29	1
4	Panel framework	12	1
5	Horizontal protection plate	7	1
6	Roof "Big City" 2x2m (acrylic)	133	1
7	Handle		4
8	Angle fence (plastic)	20	2
9	Step bottom	2	2
10	Footboard	3	1
11	Big tower support	12	11
12	Panel "Illuminator" assembly		1
13	Angle fence - net (1,04*1m)	13	1
14	Angle panel with illumination	25	1
15	Fence-plastic (0,8m)	13	2
16	Brace rod 0,8m (Big city)	1	3
17	Small fence frame	10	1
18	Ladder handrail frame	11	1
19	Ladder handle		2
20	Side top beam	10	3
21	Side top beam	10	2
22	Beam	2	2
23	Armature 16 L=4000 DSTU3760		11
24	Angle bearing element 40x60		12
25	Beam cap TE830		2
26	Beam 1,6m (cut 0,7m)	9	1
27	Overlap (0,4x0,9)	5	2
28	Step (200x787)	2	2
29	Angle plate		20
30	Brace rod D15x87 mm		40
31	Beam 3,225m	19	1
32	Beam 3,225m	19	2
33	Beam 3,225m	19	1
34	Beam 3,225m		1
35	Beam 3,225m	19	2

Pos.	Name	Weight	Q-ty
36	Central beam3,225m	19	2
37	Central top beam	15	3
38	Attached top beam	10	1
39	Attached top beam	19	1
40	External central top beam	10	1
41	Panel "Sewing"	21	1
42	Fence panel	4	1
43	Panel "Fence"	7	2
44	Panel "Cat at the steps"	4	1
45	Panel "Cat at the steps"	4	1
46	Plug 25x40		10
47	Cap M8		138
48	Cup M8		138
49	Pivot M8 L=135		44
50	Stud M8*25.A2-70 DIN7991 (c-sunk) stainless s.		80
51	Screw 6x60 SPAX T-STAR plus (flat, TX30)		96
52	Screw 8*70-A2 DIN 571 (6-sided) stainless steel		18
53	Screw 8*100-A2 DIN 571 (6-sided) stainless steel		4
54	Screw 8*140-A2 DIN 571 (6-sided) stainless steel		2
55	Washer 8-A2 DIN9021 (enlarged)		1
56	Bolt M8*130.A2-70 DIN 603(furn.) stainless steel		20
57	Bolt M8*150.A2-70 DIN 603(furn.) stainless steel		6
58	Screw 4*40-A2 DIN 7997 (c-sunk-univ, PZ)st.s.		28
59	Stud M8*30.A2-70 ISO7380 (round-head) st.s.		12
60	Stud M8*40.A2-70 ISO7380 (round-head) st.s.		3
61	Stud M8*50.A2-70 ISO7380 (round-head) st.s.		6
62	Bolt M8*70.A2-70 DIN933 (6-sided full thr.) st.s.		4
63	Bolt M8*30.A2-70 DIN603 (furn.) stainless steel		4
64	Bolt M8*65.A2-70 DIN603 (furn.) stainless steel		6
65	Nut M8.A2-70 DIN934 (6-sided) stainless steel		129
66	Washer 10-A2 DIN 125 (flat)		138
67	Screw 4,8*32.C1 DIN7504P(c-sunk+bore TX)s.s.		28
68	Washer 8-A2 DIN 125 (flat)		34
69	Nut M8.A2-70 DIN 1587 (cap) stainless steel		16
70	Washer 10-A2 DIN 9021 (enlarged)		25

Picture 32

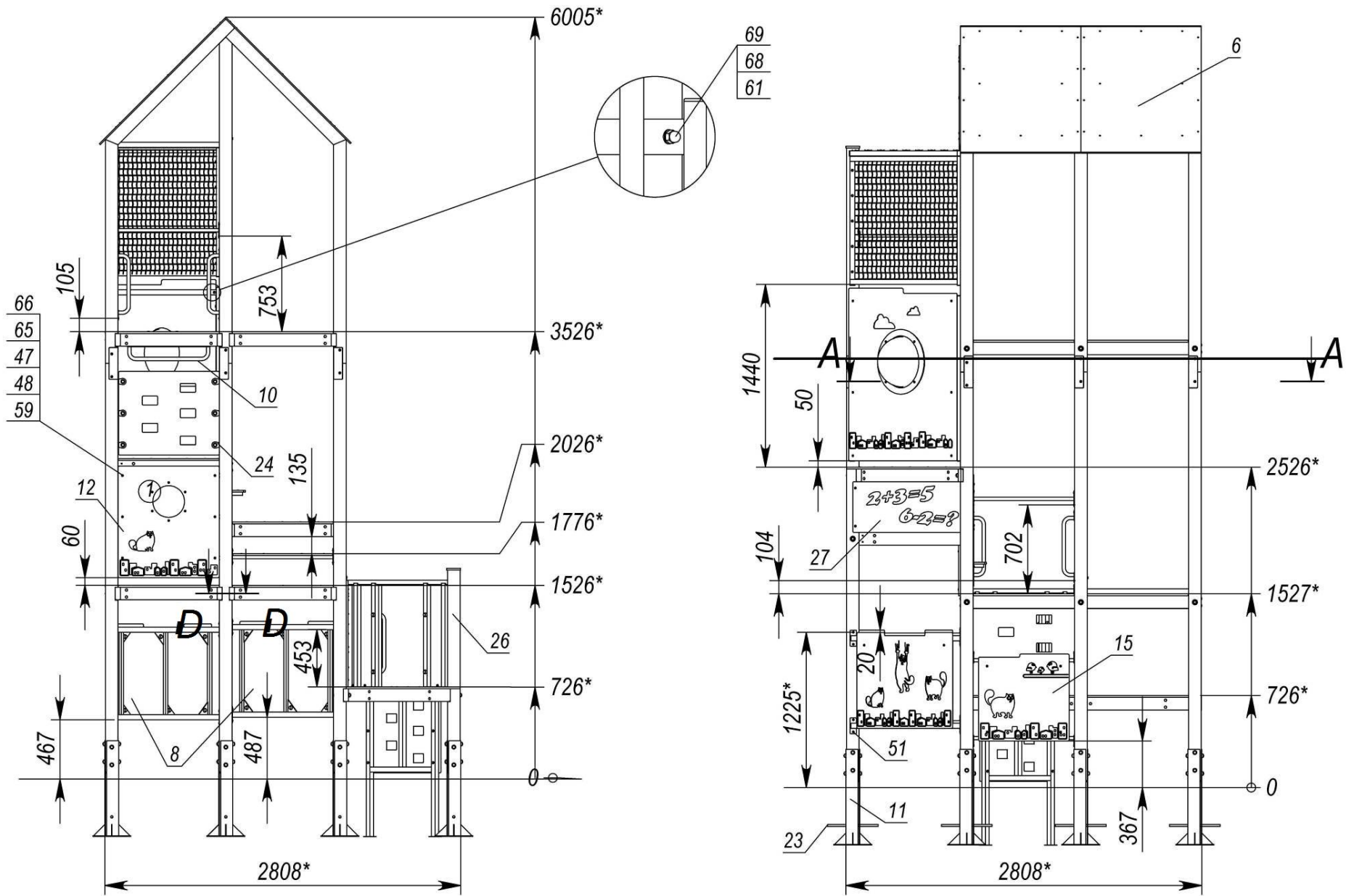

Picture 33

(1 : 10)

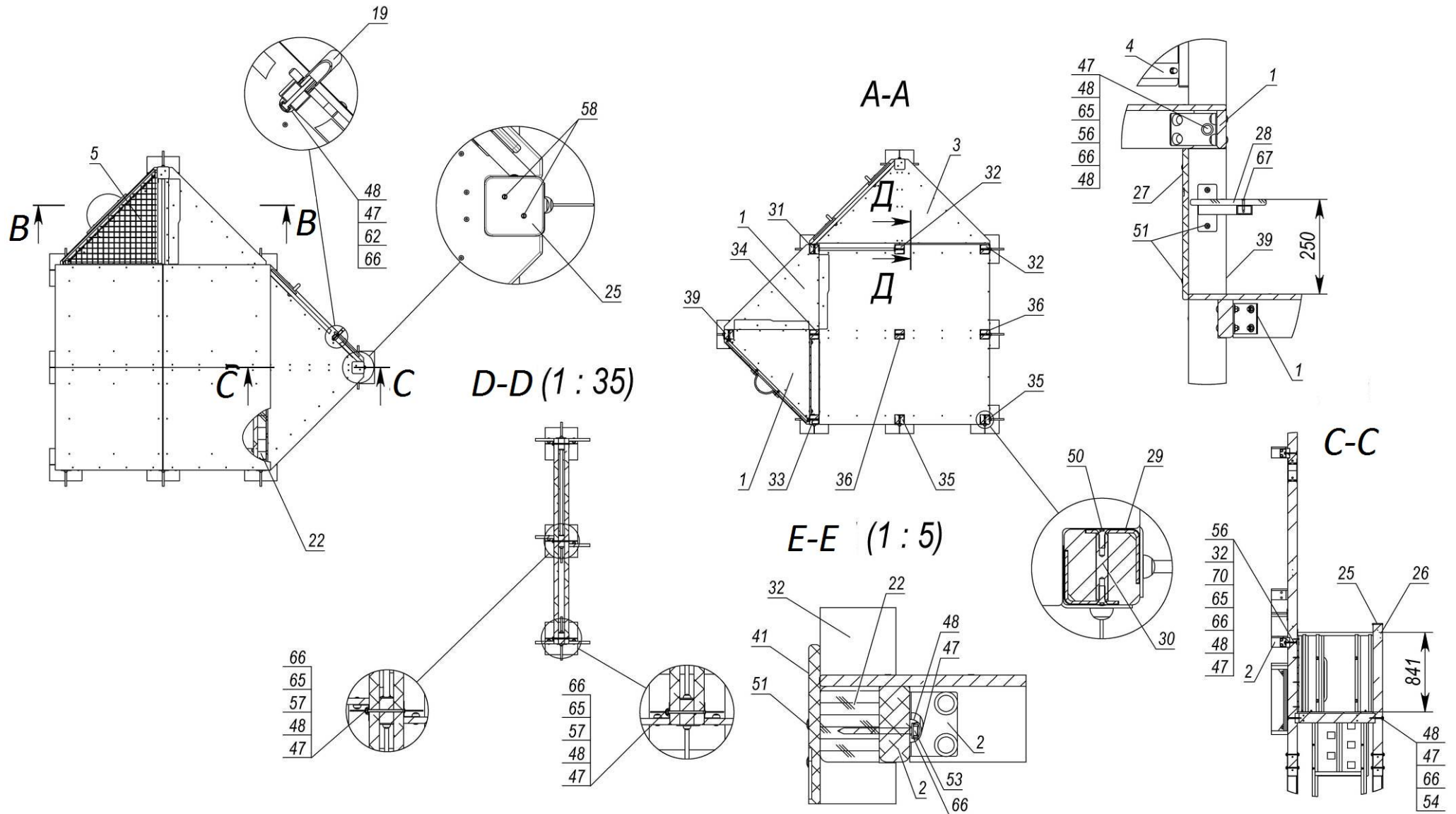

Picture 34

(1 : 10)

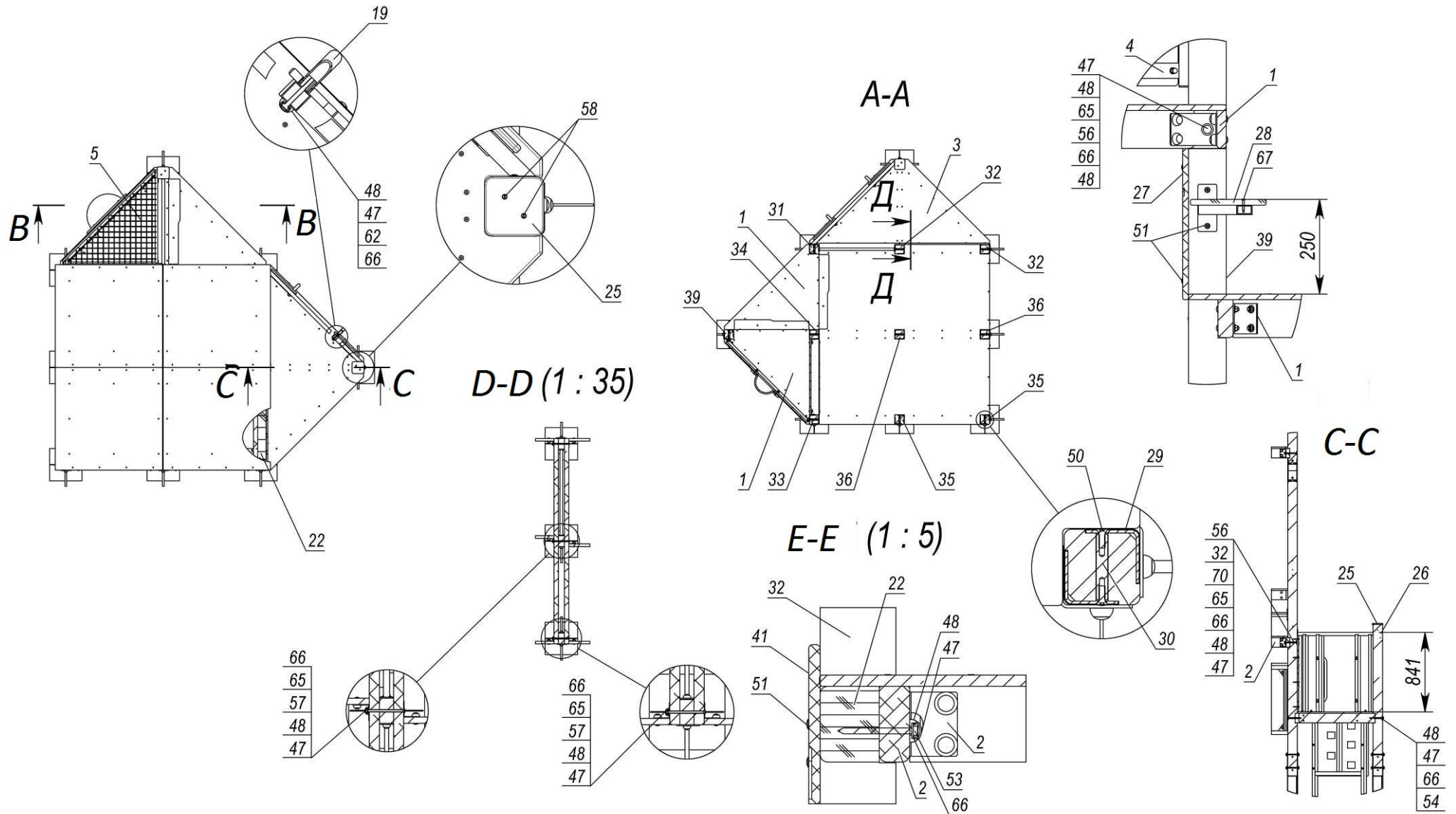

Picture 35